

INDUSTRIAL SEWING MACHINE

MODEL

PLK-J-CU-20

TECHNICAL MANUAL

Control Unit

[1] For safe use	[1]-1
[2] Precautions for use	[2]-1
[3] Installation	[3]-1
[4] Names of each part, wiring and grounding	[4]-1
[5] Confirmation	[5]-1
[6] Main and Sub servo motor	[6]-1
[7] Timing chart	[7]-1
[8] Customized input/output	[8]-1
[9] Input / Output signal	[9]-1
[10] What happened? Could it be an error?	[10]-1
[11] How to reinstalling the system	[11]-1
1. Control box install	[11]-2
2. PAL install	[11]-3
3. I/F board (MIF) Install	[11]-4
4. Confirm version information	[11]-5
5. Initialize settings.....	[11]-6
[12] Several power supply	[12]-1
[13] Unit wiring diagram	[13]-1
[14] Connectors layout	[14]-1
[15] Pin number of connectors	[15]-1
[16] Wiring diagram inside control box	[16]-1
[17] Specifications	[17]-1

Thank you for purchasing the Mitsubishi industrial sewing machine PLK-J Series.
Please read this technical manual before starting to ensure correct and long-term use.

- * The contents of this manual may not be reproduced in part or whole.
- * The contents of this manual are subject to change without notice.
- * An utmost effort has been made to cover all points of operation in this manual. Contact Mitsubishi if you have any questions regarding the contents.

COPYRIGHT(C) 2017-2019 MITSUBISHI ELECTRIC CORPORATION

[1] For safe use

■ For safe use

Always observe the following matters to safely use the Mitsubishi industrial electronic sewing machine PLK-J Series.

Before starting

Before using this control unit, read all of the technical manuals carefully, and correctly use the unit following the manual. Also read the "Mitsubishi Industrial Sewing Machine Technical Manual <Sewing Machine Head>" for details on the general configuration and sewing machine head.

Application and purpose

This control unit is designed to drive and control the Mitsubishi industrial electronic sewing machine PLK-J Series. Do not use this control unit for other applications or purposes. Do not use this control unit until it has been confirmed that safety measures have been accurately taken for the installed electronic sewing machine head section.

Working environment

Please use this control unit in the industrial setting only. And do not use this control unit in the following type of environment.

(1) Power voltage

- * Where the voltage fluctuation exceeds $\pm 10\%$ of the rated voltage.
- * Where the specified power capacity (Refer to page [4] - 2) cannot be ensured.

(2) Magnetic noise

- * Where strong fields or magnetic fields are generated, such as near a high-output high frequency oscillating machine or high frequency welder.

(3) Temperature and humidity

- * Please use the ambient temperature in more than 5°C and 35°C or less.
If it is used outside the above ambient temperature, the sewing machine will detect temperature abnormality and protection of the sewing machine may be applied so that operation can not be performed.
- * Where the unit will be subject to direct sunlight, or outdoors.
- * Near sources of heat, such as heating appliances.
- * Where the relative humidity is 45% or less, or 85% or more, and where dew may condense.

(4) Atmosphere

- * In an atmosphere containing dust or corrosive gases, etc.
- * In a flammable gas or explosive environment.

(5) Vibration

- * If excessive vibration could occur when installed on the sewing machine, separately install the control box.

■ Installation

Control box

Correctly install the control box according to this manual.

Accessories

Always disconnect the control unit from the main power supply before installing the accessories listed in this manual. "Turn the power switch OFF, and disconnect the plug from the socket (power supply line)."

Cable

- (1) Lay the connection cables so that excessive force will not be applied during operation. Do not excessively bend the cables.
- (2) Cables laid near operating machine sections must be separated by at least 25mm.
- (3) Before connecting the power cable to the control box, confirm that the power voltage matches the specifications given on the control box's rating nameplate and factory shipment voltage nameplate. Connect the cable to the indicated positions, and then supply the power. When using a power unit, connect the cable to the power unit and supply the power. In addition, when using a power unit, confirm that the power voltage matches the specifications given on the power unit's rating nameplate. Turn the power switch OFF before making any connections.

Grounding

Always ground the power cord's grounding wire.

Enclosed units and accessories

Connect the electrical enclosed units and accessories only to the positions indicated in the manual.

Removal

- (1) Always turn the power switch OFF and disconnect the plug from the socket (power supply line) before removing the control box.
- (2) Do not pull out the cord when disconnecting the plug. Always hold the plug receptacle when disconnecting the plug.
- (3) Note that a high voltage is applied inside the control panel, **so always turn the power OFF and wait at least ten minutes before opening the control box cover.**

■ NOTICE CONCERNING CE MARKING

- (1) Electronic sewing machine PLK-J series are applied to CE conformity marking by installing the exclusive device [PLK-J-CE] and [PLK-J-ACR].
When the products are used in the EU region, these devices are necessary to be installed.
- (2) Electronic sewing machine should be use limited to the industrial areas even though above-mentioned countermeasure is done.
[Warning] Use in residential areas may cause interference.

■ Maintenance, inspection and repairs



- (1) Follow this manual when carrying out maintenance or inspections related to this control unit.
- (2) This unit must be repaired, serviced and inspected only by a worker that has received special training.
- (3) Always turn the power OFF before replacing the needle or bobbin, etc., on the head.
- (4) Use genuine replacement parts for repairs and maintenance.

■ Other safety measures





- (1) Keep fingers away from all moving machine parts (especially around the sewing machine needle, etc.).
- (2) Never drop the control unit, or place objects in the clearances.
- (3) Do not operate the sewing machine without the protective parts such as the cover, or protection devices such as the safety breaker.
- (4) If any damage is observed in the control unit, if the unit does not operate correctly, or if the operation is suspicious, always suspend operation. Only operate the machine after the supervisor has adjusted, repaired or inspected the machine.
- (5) The user must not make improvements or changes without instruction from Mitsubishi.

■ Caution displays and danger displays

- (1) In this manual, the dangers and danger levels that arise with incorrect handling are classified using the following displays.

 Warning	The warning display shows that incorrect handling can lead to death or serious injuries.
 Caution	The caution display shows that incorrect handling can lead to injuries or damages to your house, household goods, and others.

- (2) The meanings of these symbols are as follows.

	This symbol indicates that the instructions must be followed.		This symbol indicates an electrical hazard or caution (electric shock caution).
	This symbol indicates hot temperature requiring caution.		This symbol indicates that ground wire connection is required.
	This symbol indicates a prohibited action.		

* Always deliver this manual to the end user.

* Store this manual nearby where it can be referred to when necessary.

[2] Precautions for use

Warning

1. Do not place foot on the foot switch when turning the power ON.

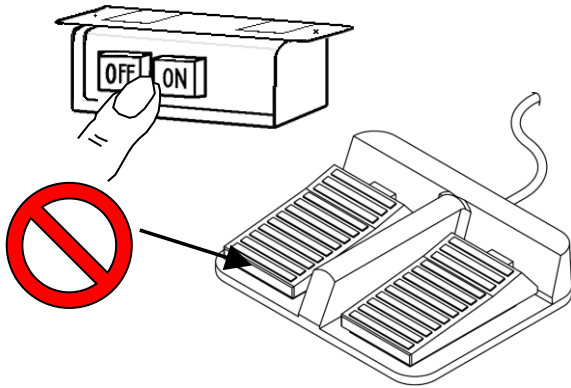

2. Always turn the power OFF when leaving the sewing machine.

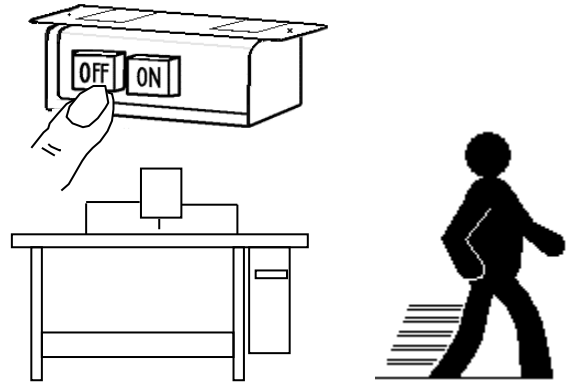

3. Do not inspect the control circuit with a tester.

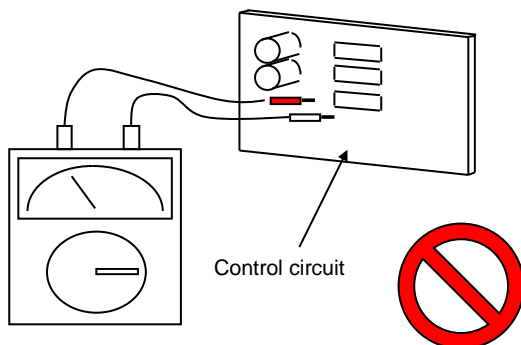

The tester voltage could be applied on the semiconductor parts, and cause damage.

4. Always turn the power switch OFF before tilting the sewing machine head, replacing the needle, or passing thread through the needle.

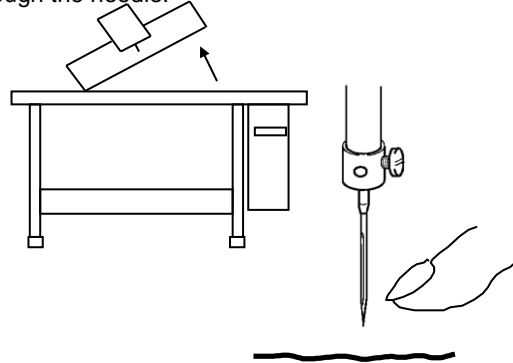

5. Always ground the grounding wire.

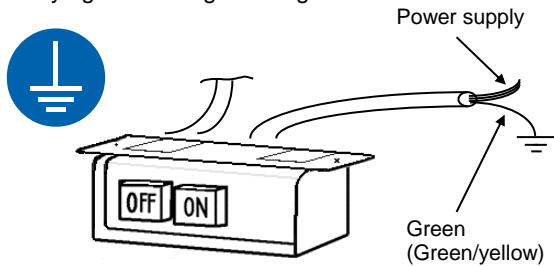

Always ground the provided grounding wire (green(green/yellow)).

6. Do not use excessive wiring.

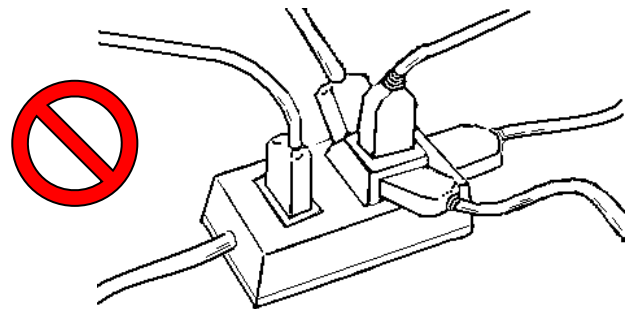

7. A high voltage is applied inside creating a hazardous state, so always turn the power OFF and wait ten minutes before opening the cover.

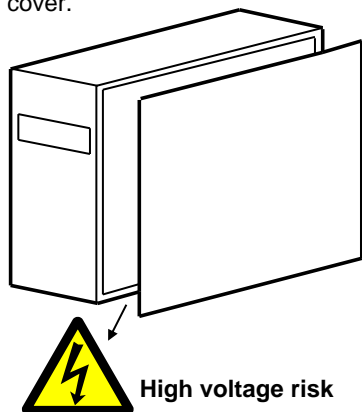

High voltage risk

8. Radiation fins and other parts may be hot. Do not touch the parts.

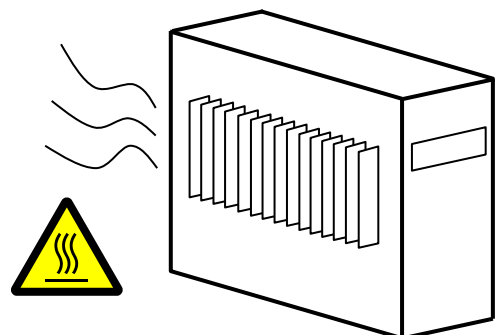

9. The sewing machine will coast to a stop when the power is turned OFF or a power failure occurs during sewing machine operation.

10. Always align the connector shape and direction, and securely insert the connector.

11. If the position detector's connector dislocates, or the sewing machine is completely locked, the motor will be turned OFF automatically for a set time to prevent burning. (Note that the motor may not turn OFF if there is incomplete locking or an overload.) When the fault has been recovered, turn the power OFF and ON once to resume normal operation. The same type of operation will take place if a detector fault or disconnection occurs.

12. Use the machine away from strong noise sources such as high frequency welders.

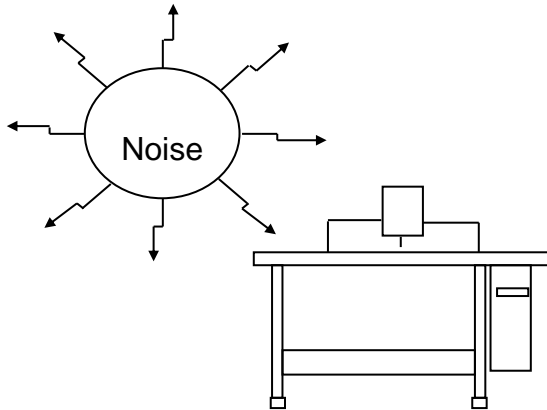

13. When connecting the external switch to an optional connector, etc., keep the signal wire as short as possible. A long wire could cause malfunctions.

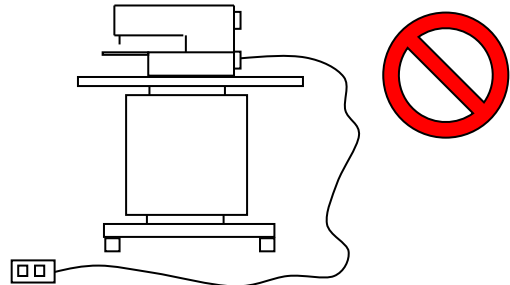

Use a shielded wire for the signal wire when possible.

14. If the fuse blows, remove the cause, and replace the blown fuse with one having the same capacity.

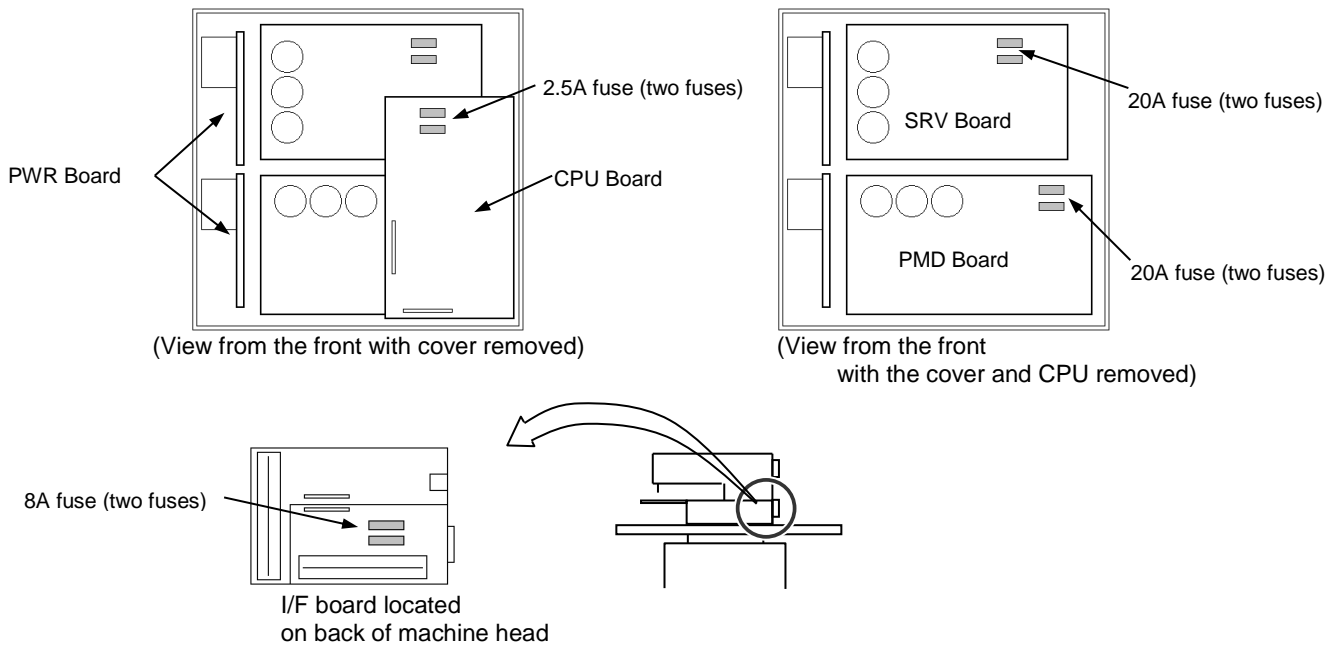

15. Attention when power supply is turned on again

Please make sure not to turn on the power supply switch until after the LED on the front panel of the control box has completely turned off.
(Please do not turn on the power supply again while displaying the screen of the operation panel.)

* If the above operation is not observed, the presser foot (O4 output) may move unexpectedly.

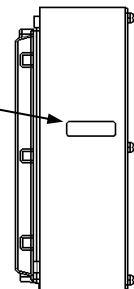

16. **When the value of the sewing area limit is changed or the limit setting is deactivated, note the collision and take care safely.**
Also when using it outside the range where the mechanism can be operated, it cannot assume the responsibility for all problems caused by it.

[3] Installation

1. Installing the control box

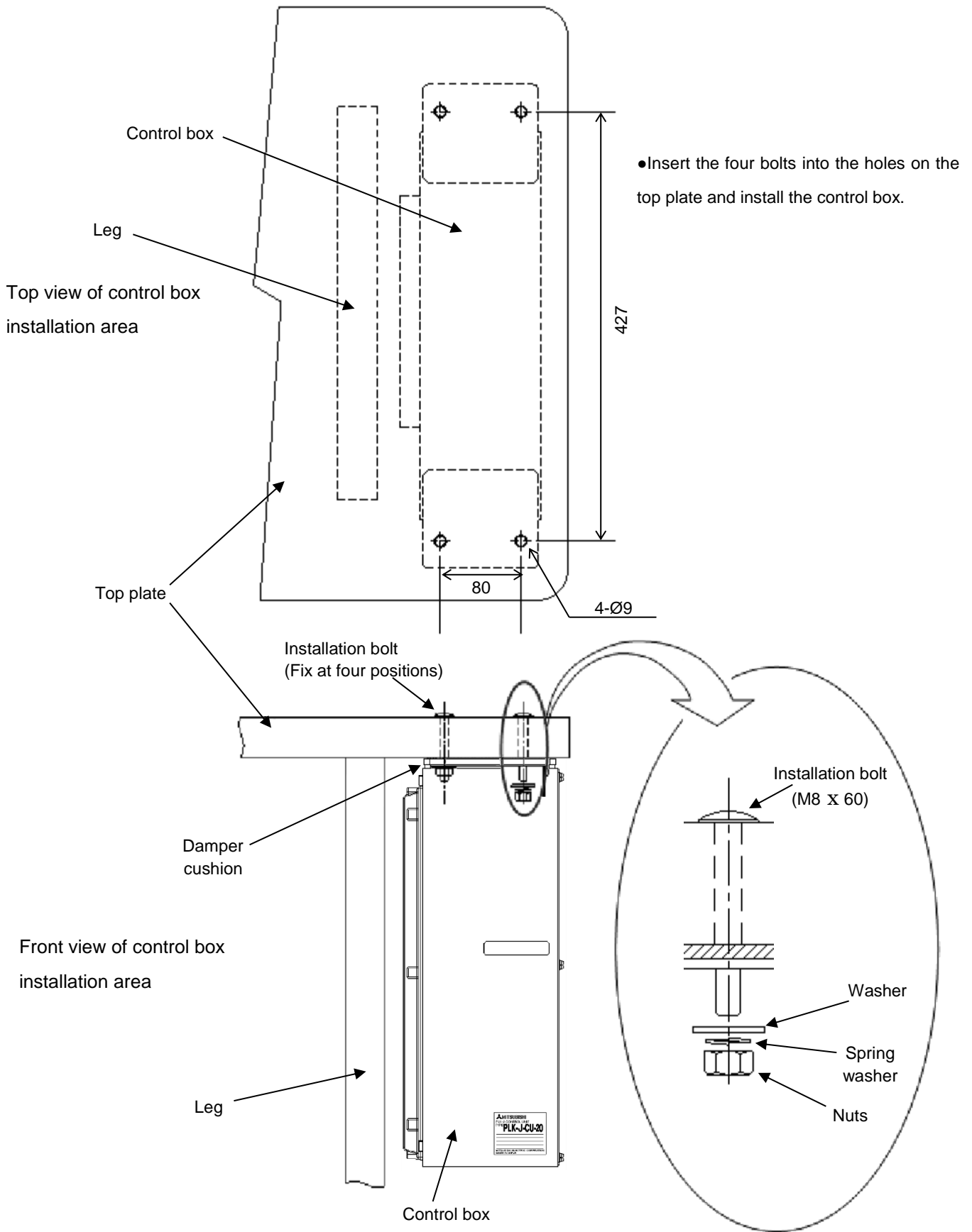

[4] Names of each part, wiring and grounding

1. Front side

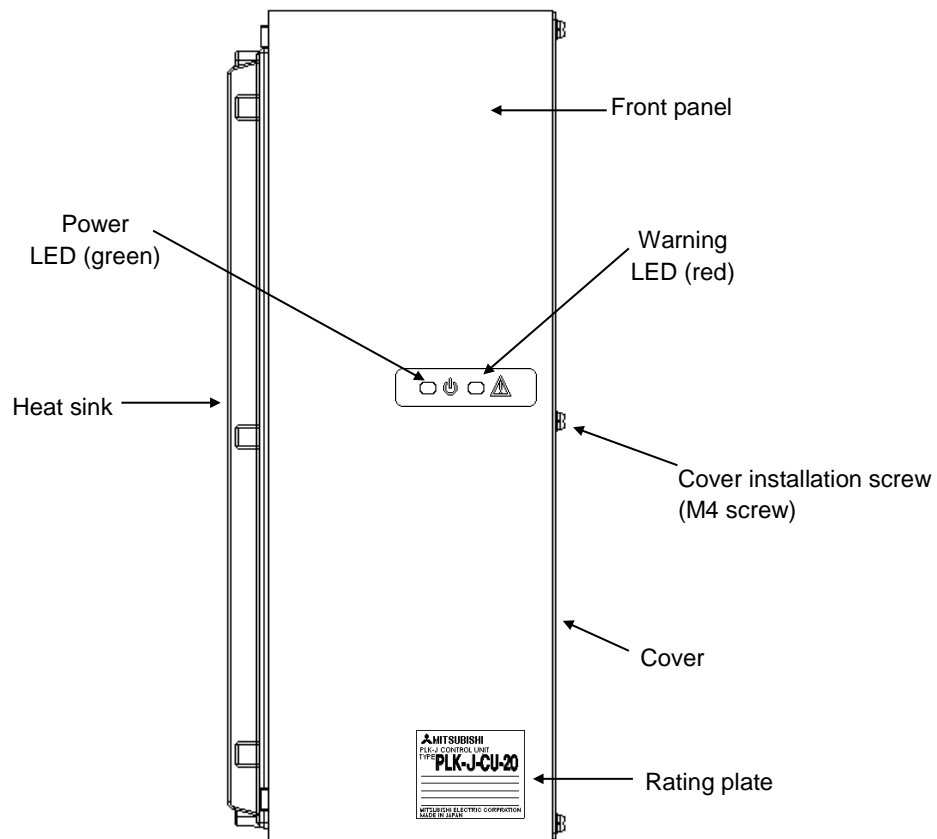

2. Back side

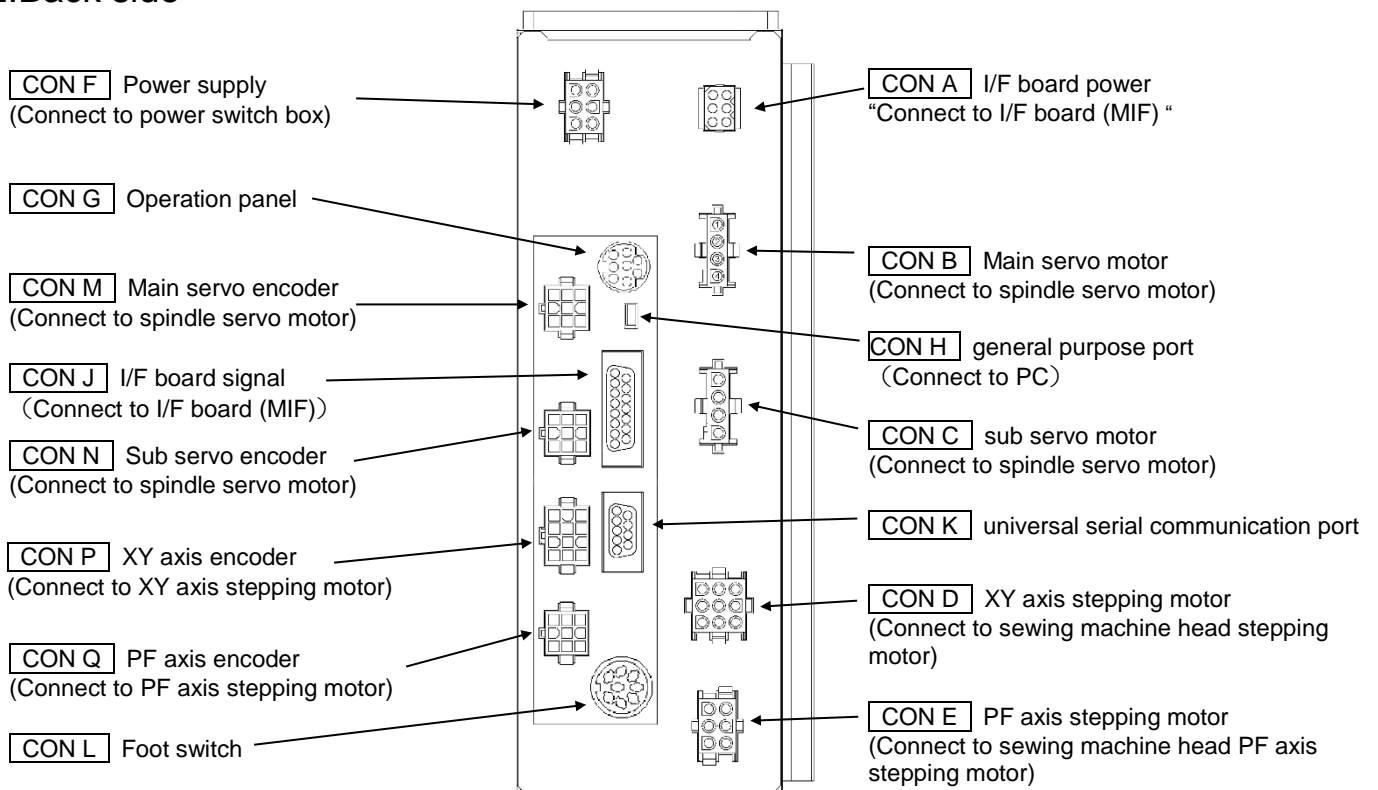

Caution: Be sure to connect all connectors before turning ON the power. Connect each connector fully to ensure sufficient contact. Refer to "section [13]."

3. Connecting the power connector

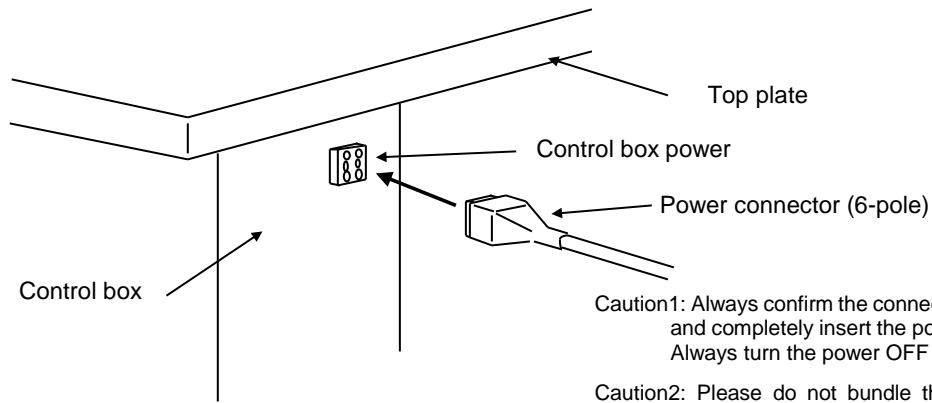

Caution1: Always confirm the connector shape and insertion orientation and completely insert the power connector into the control box. Always turn the power OFF before connecting the connector.

Caution2: Please do not bundle the power cable and other cables together. It may cause of malfunction by the influence of the power supply noise etc.

4. Connecting the 3-phase power supply

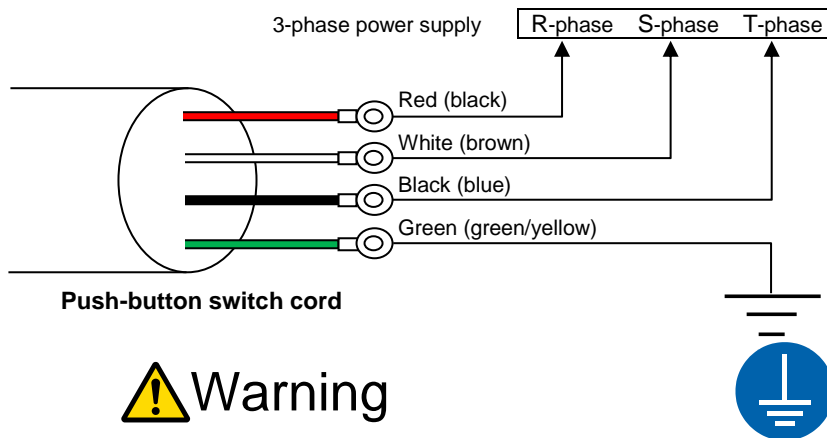

Warning

Always connect the green wire to the grounding terminal.
Consult with your electrician for details on the grounding wire.

5. Power capacity

Use a fuse or safety breaker on the power supply.

Power supply	Recommended current capacity value
3-phase 200V	10A

6. Using the 3-phase 200V control box with single-phase 200 to 220V

Connect power supply to the "red" and "white" lead wires for the push-button switch. The black wire is not used, so insulate it by wrapping insulation tape, etc., around it. Always ground the green grounding wire.

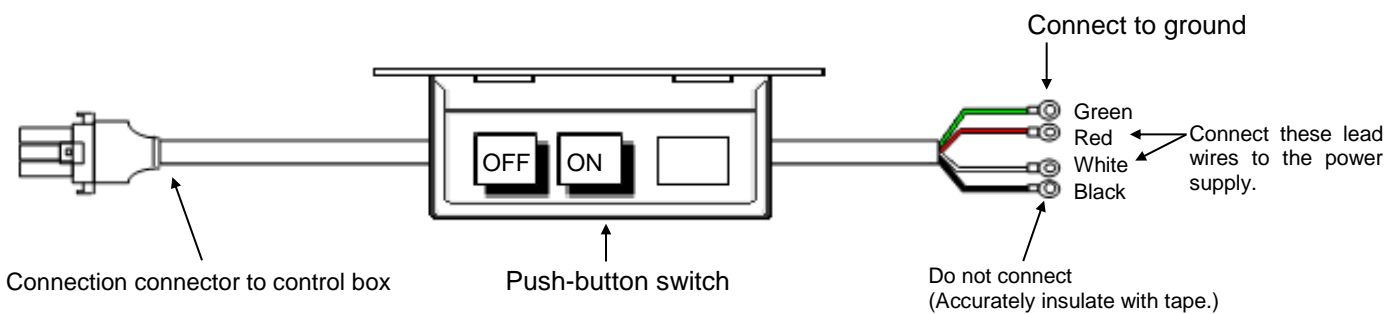

[5] Confirmation

1. Before turning the switch ON

(1) Are the power and capacity correct?

(2) Are the connectors correctly inserted? (Refer to "section [12]".)

- * Power connector from push-button switch
- * Connector for connection with sewing machine
- * Operation panel connector
- * Foot switch connector
- * Other connectors "I/F board (MIF), etc."

(3) Does the hand pulley turn easily?

2. After turning the switch ON

(1) Is the front panel power LED (green) on?

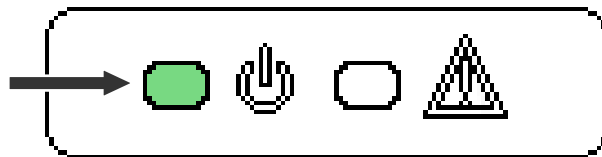

(2) Is the front panel warning LED (red) on or flickering?

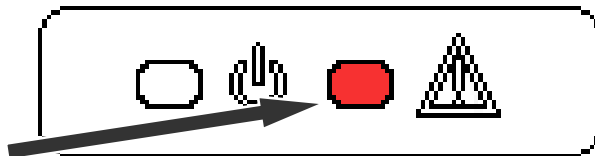

(3) Is there any heating, odors or abnormal noise from the motor or control box?

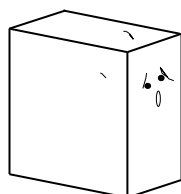

Turn the sewing machine OFF and contact your dealer if there is any heating, odors or abnormal noise.

- When you turn ON the power, a click noise comes from inside the control box.
This noises are not abnormal.

[6] Main and Sub servo motor

Main and Sub servo motor are driven by independent.

Please note the timing for motion of each motors.

Refer the other technical manual "Sewing Machine Head" about details.

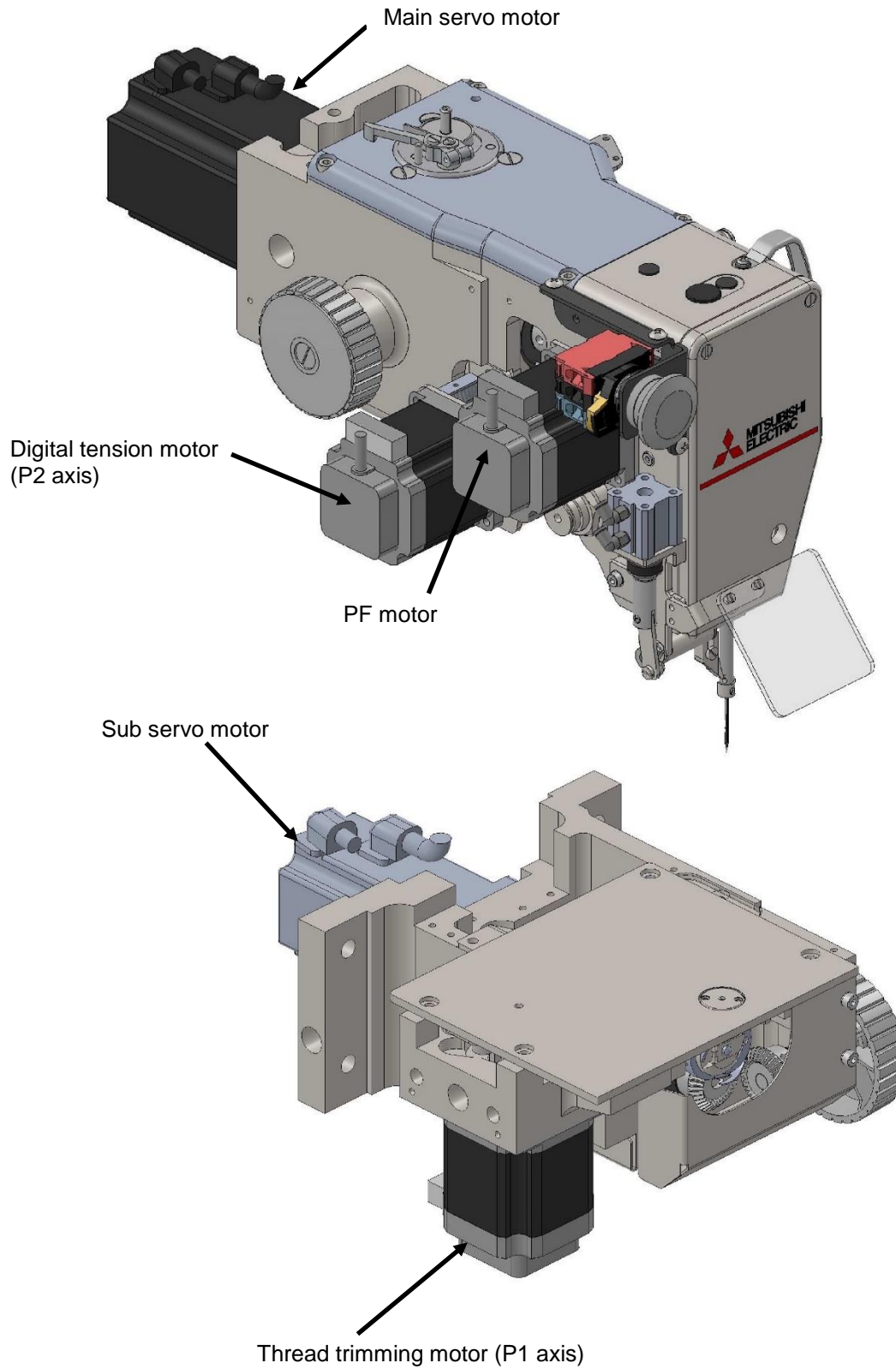

[7] Timing chart

1. Thread trimming timing chart

-Timing for thread trimming output [T] :

Program mode [Thread trimming/release timing] -- [LTM] T1~T5
 Program mode [Thread trimming/release timing] -- [TRS] msec / deg
 Program mode [Thread trimming/release timing] -- [TRE] msec / deg

-Timing for thread release output [L] :

Program mode [Thread trimming/release timing] -- [LLM] L1~L5
 Program mode [Thread trimming/release timing] -- [LRS] msec / deg
 Program mode [Thread trimming/release timing] -- [LRE] msec / deg

-Timing for wiper output [W] :

Program mode [Wiper] -- [W1] msec
 Program mode [Wiper] -- [W2] msec

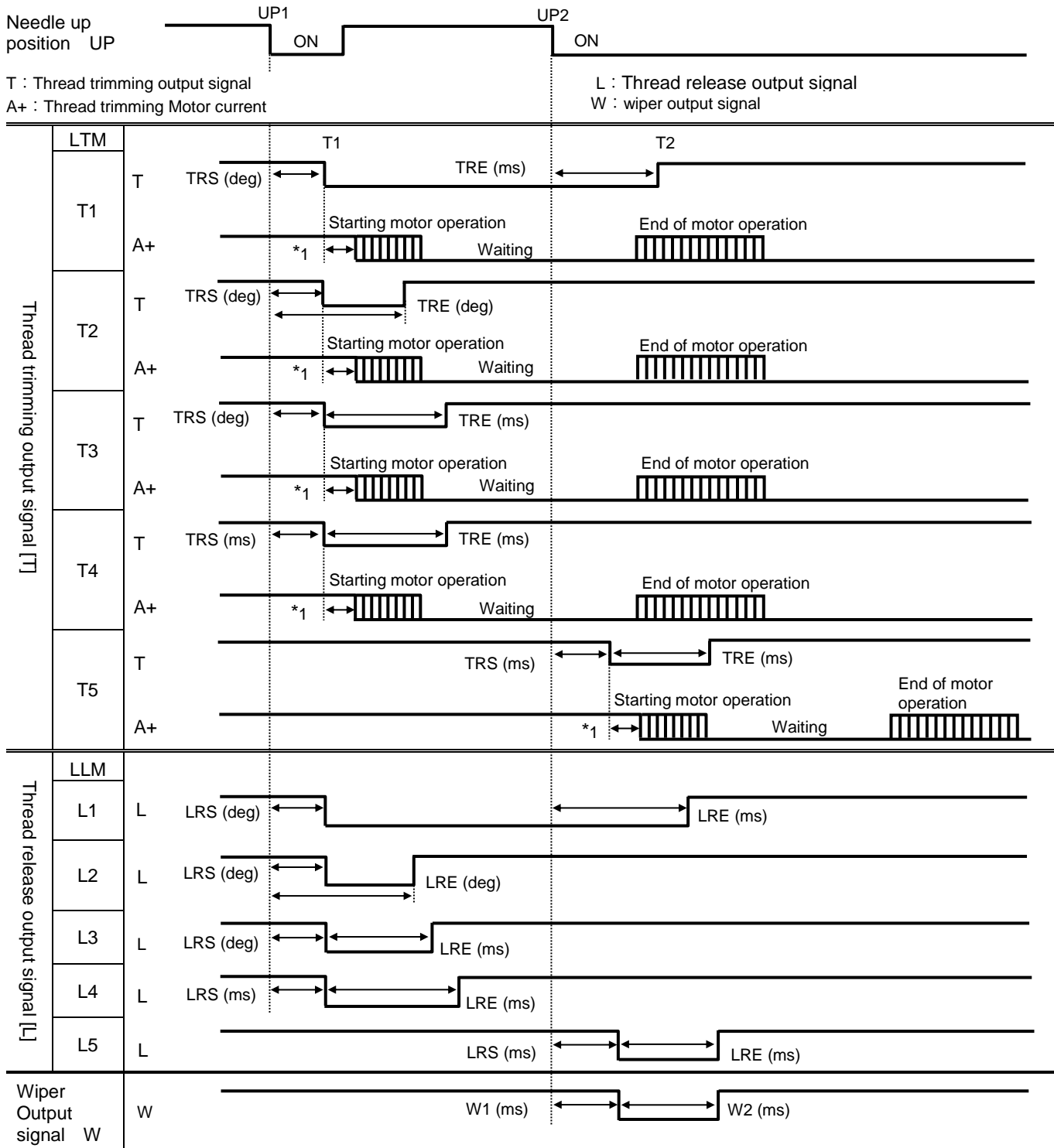

*1: Thread trimming motor start to move after delay time (about 25 msec) of Trim output turning ON.

Note: Thread trimming motor is driven by independent.

Please note the setting about trim speed and trim timing.

2. Timing chart for [Clamp of output ON/OFF delay setting]

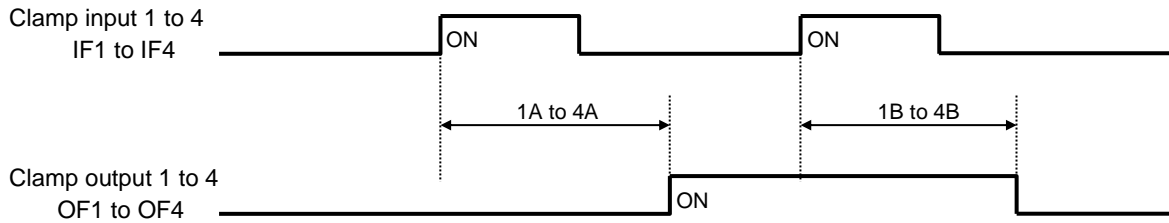

3. Timing chart for [Priority of clamp]

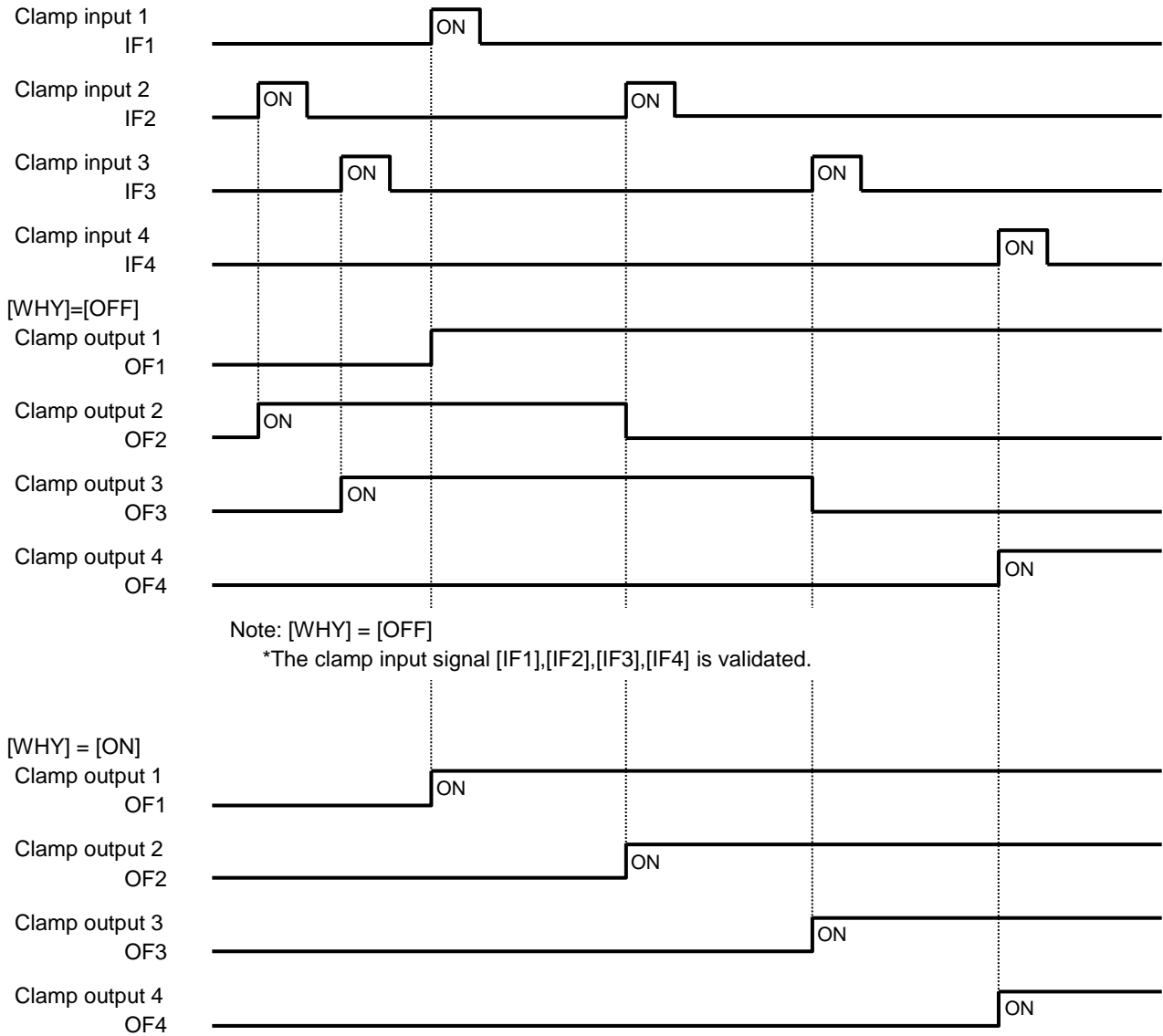

Note: [WHY]=[ON]

The clamp input signal [IF2],[IF3],[IF4] is invalidated when clamp output 1 is not ON.
 The clamp input signal [IF2] is validated when clamp output 1 is ON.
 The clamp input signal [IF3] is validated when clamp output 2 is ON.
 The clamp input signal [IF4] is validated when clamp output 3 is ON.

4. Timing chart for

[Clamp link setting (CF)] = ON, [Valid Number of clamp setting (FN)] = 4

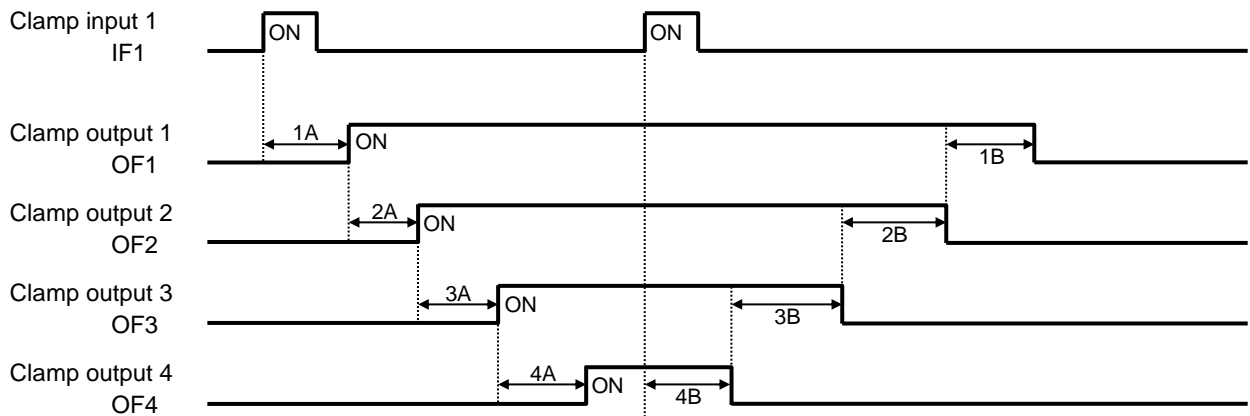

Note: Halt switch is validated.

5. Timing chart for

[Selection of pneumatic pressure two-step (AF2)] = ON

Can not use other function in "Work holder" mode.

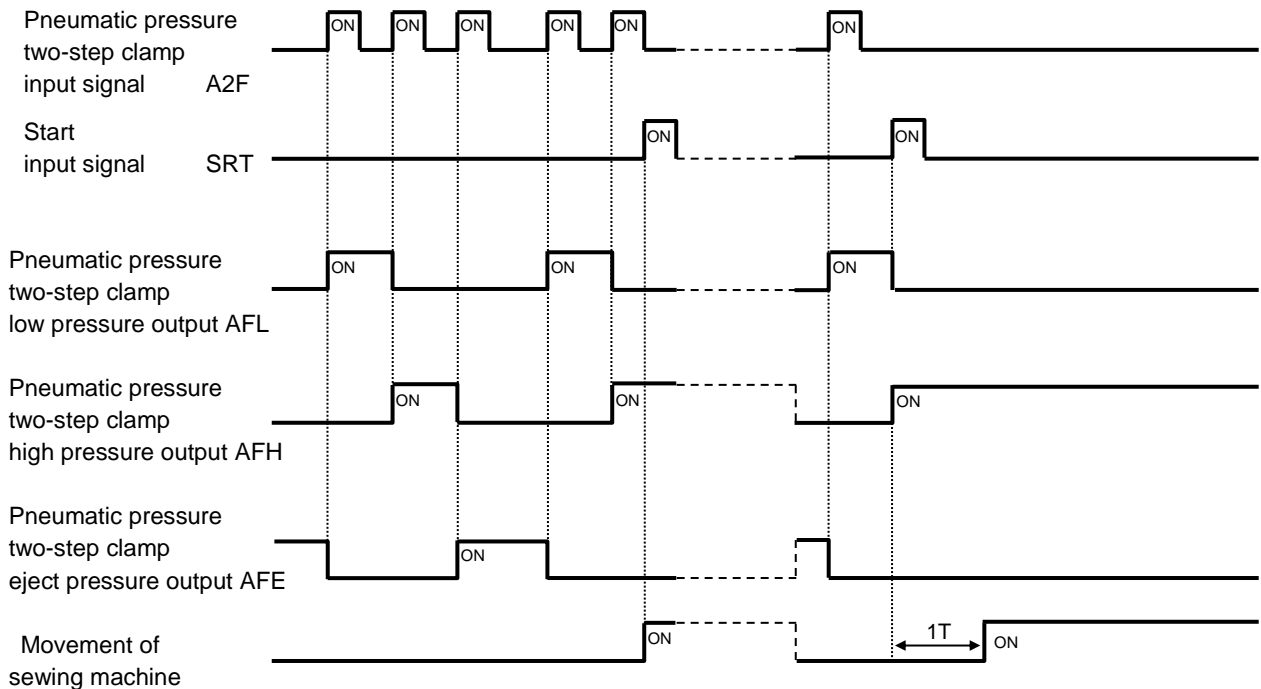

6. The divisions of clamp setting [OFB] = 4

Setting of [FN],[CF] is invalidated when above setting.

Clamp(O1,O2),(O3,O4) is link movement when above setting.

The presser block to be used is [F2BN] and can be set.

[WHY] = OF,[OFB] = 4,[F2BN] = 2

When not using the clamp step input.

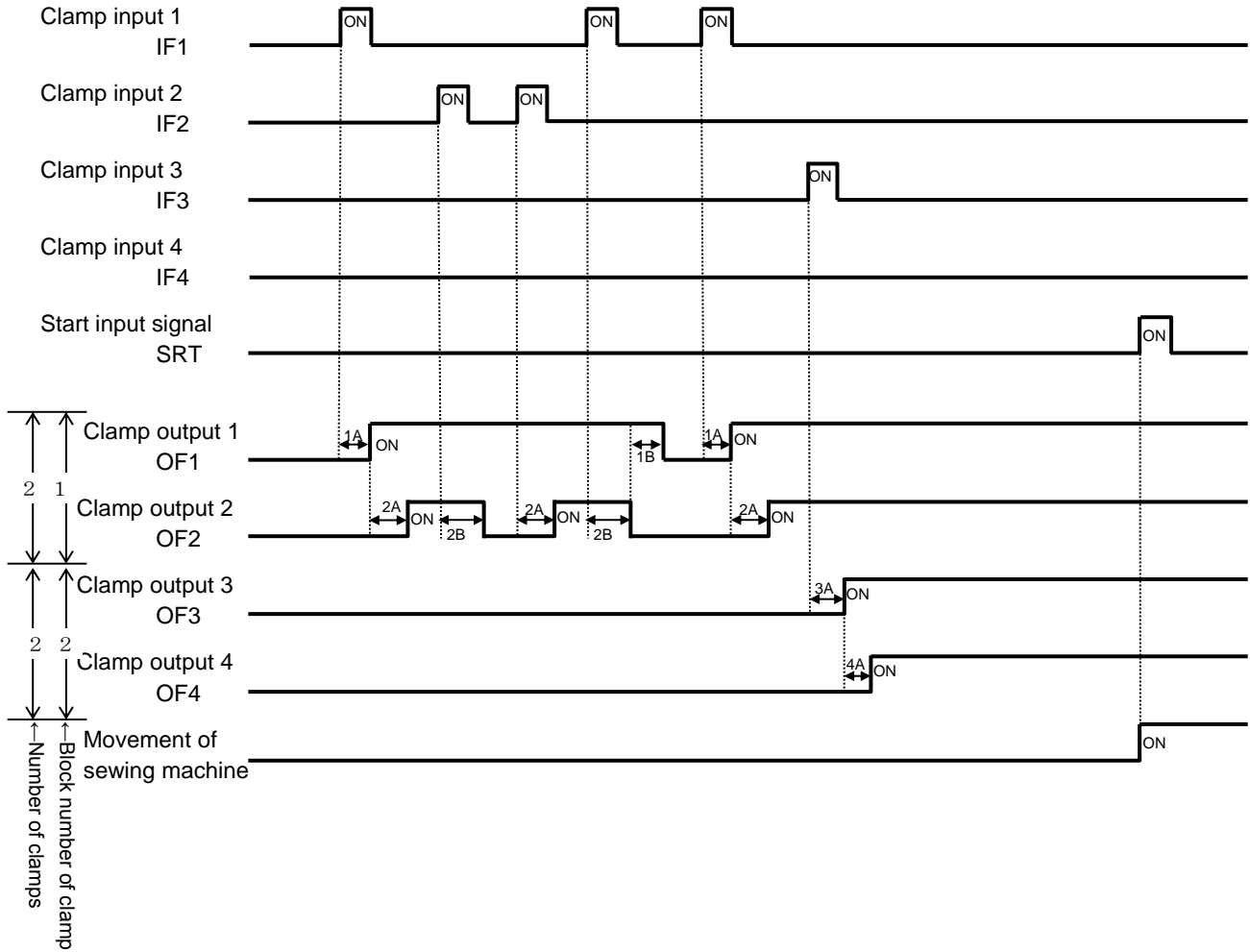

7. The divisions of clamp setting [OFB] = 4 (When using the clamp step input.)

Setting of [FN],[CF] is invalidated when above setting.

Clamp(O1,O2),(O3,O4) is link movement when above setting

The presser block to be used is [F2BN] and can be set.

The holding block that makes the clamp step motion can be set with [F2SN].

[WHY] = OF,[OFB] = 4,[F2BN] = 2,[F2SN] = 2
When not using the clamp step input.

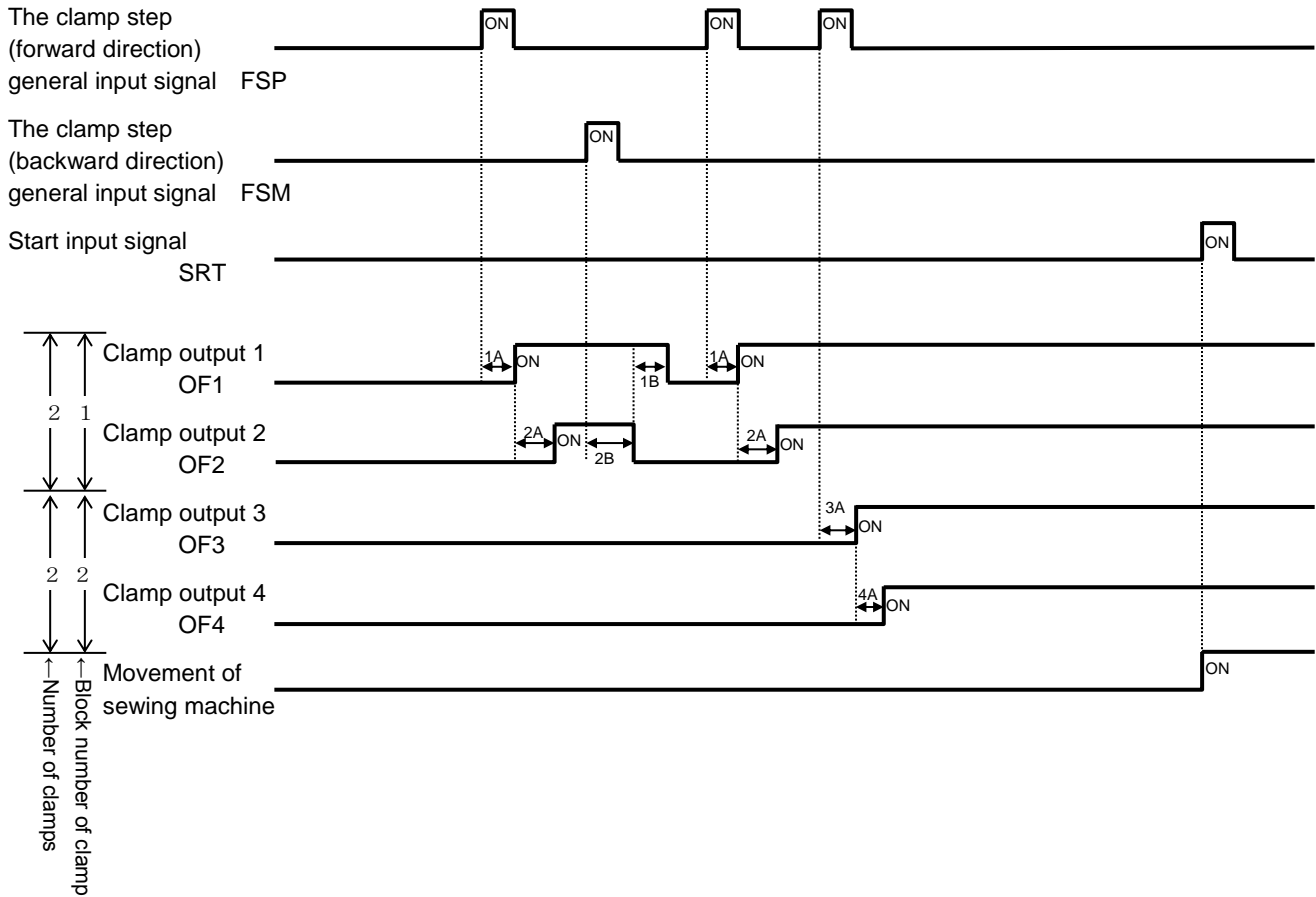

8. Oil lubrication output setting [OILV] = ON.

Oil lubricate timing set by [OL1C/2C] and [OL1T/2T].

[OL1C/2C] is not clear by after next sewing, this number is accumulate.

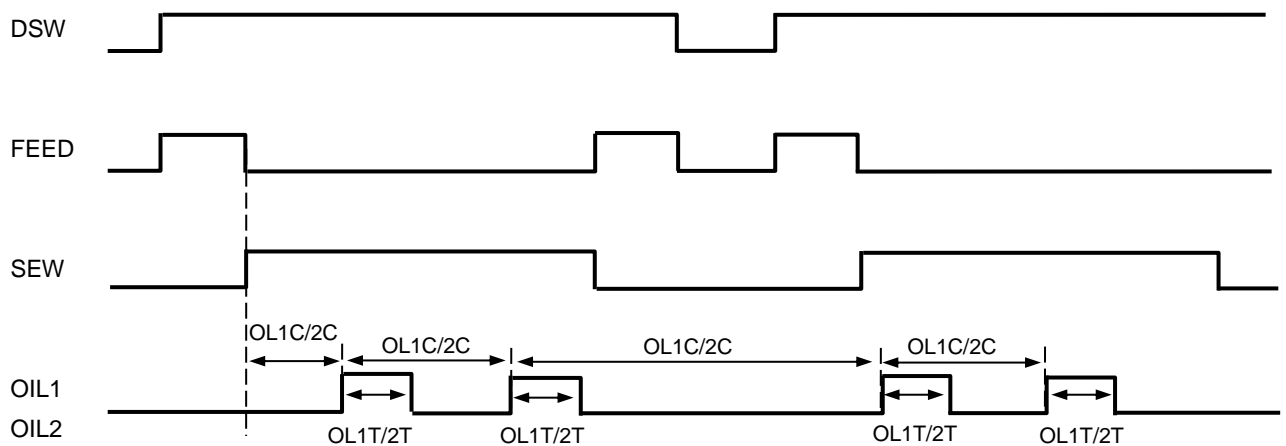

[8] Customized input/output

1. Customized input/output configuration diagram

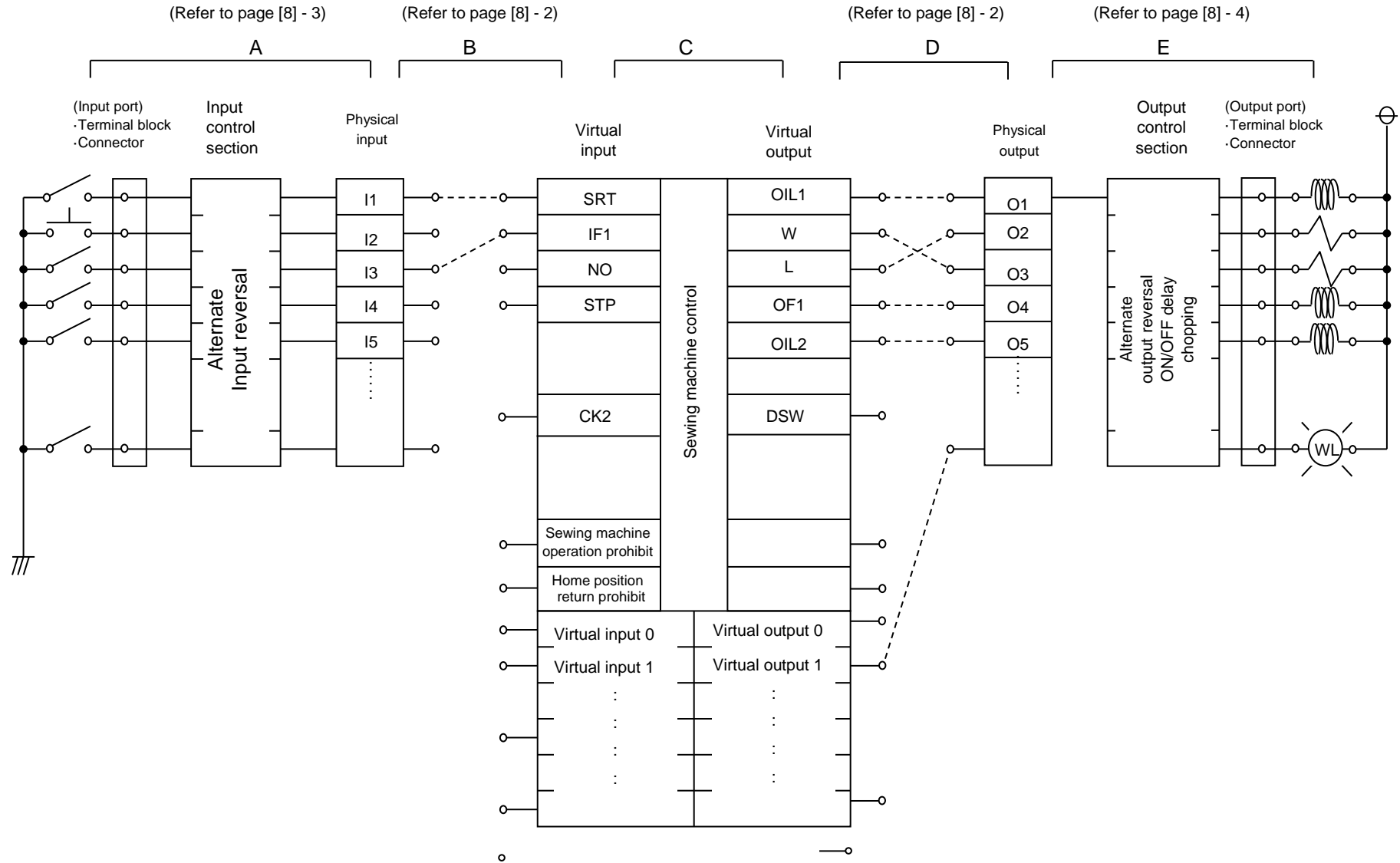

2. Outline of customized input/output mode

(A to E below correspond to A to E on the previous page.)

(1) Customizing the input signal

- A. The ON/OFF signal input from the input port passes through the input control section (no operation, alternate operation, signal reversal), and is then stored in the physical input area corresponding to the input port. (Refer to page [8] - 3)
- B. Each signal stored in the physical input area is connected to a desired position in the sewing machine control virtual input port. (Refer to page [8] - 2)
- C. The sewing machine carries out control based on the function assigned to the virtual input area.

(2) Customizing the output signal

- D. As opposed to the customized input, the virtual output area port, assigned the function, can be connected and set to a desired position in the physical output area port. (Refer to page [8] - 2)
- E. The signal for each port in the physical output area passes through the output control section (no operation, delay circuit, alternate, etc.), and is then output to the output port. (Refer to page [8] - 4)

3. Customizing the virtual input/output

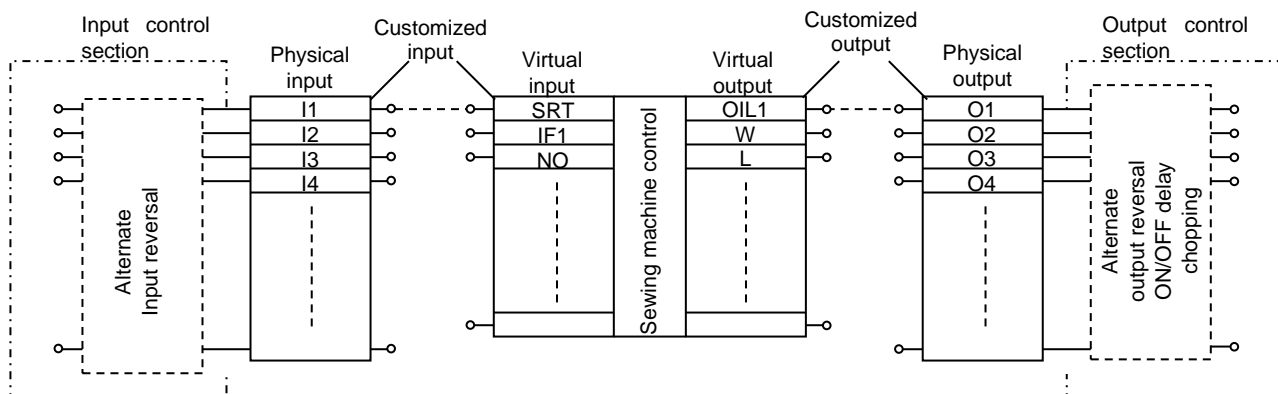

Selection and connection of physical input/output port and virtual input/output port

For example, to connect the physical input port [I1] and virtual input port [SRT] (start) and to connect the physical output port [O1] and virtual output port [T] as shown in the diagram, set as follows.

1. Using customized input, select the [I1] input functions, and set SRT.
2. Using customized output, select the [O1] input functions, and set SRT.

With the above settings, [I1] and [SRT], and [O1] and [T] will be connected.

One port from the virtual input ports can be selected for the [I*] port by changing the setting.

One port from the virtual output ports can be selected for the [O*] port by changing the setting.

4. Block diagram (input control section)

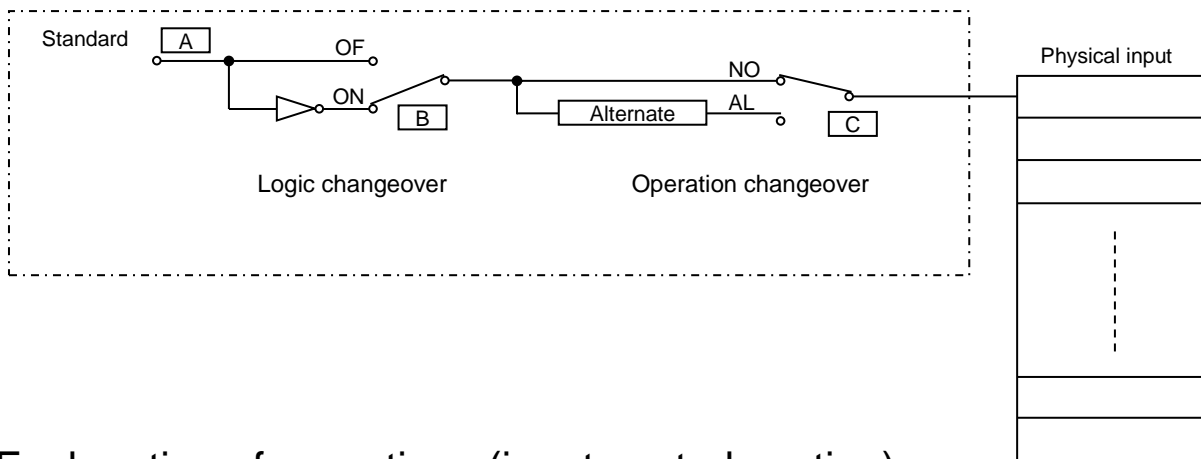

5. Explanation of operations (input control section)

The input signal passes through the A point, B point and C point of the input port, and finally is connected to the physical input

A point Inputs the signal to the input port from an external source.

B point (1) When the logic setting is set to "normal"(OF), the operation will be the same as the input signal A point.

(2) When the logic setting is set to "reverse"(ON), the operation will be the reverse of the input signal A point.

C point (1) When the operation selection is set to "normal"(NO), the operation will be the same as the input signal B point.

(2) When the operation selection is set to "alternate"(AL), the signal will turn ON at the first rising edge, turn OFF at the second rising edge, and will turn ON at the third rising edge. The signal waveform will repeatedly turn ON and OFF at the input rising edge.

The C point signal input and controlled in the above manner is input into the physical input port.

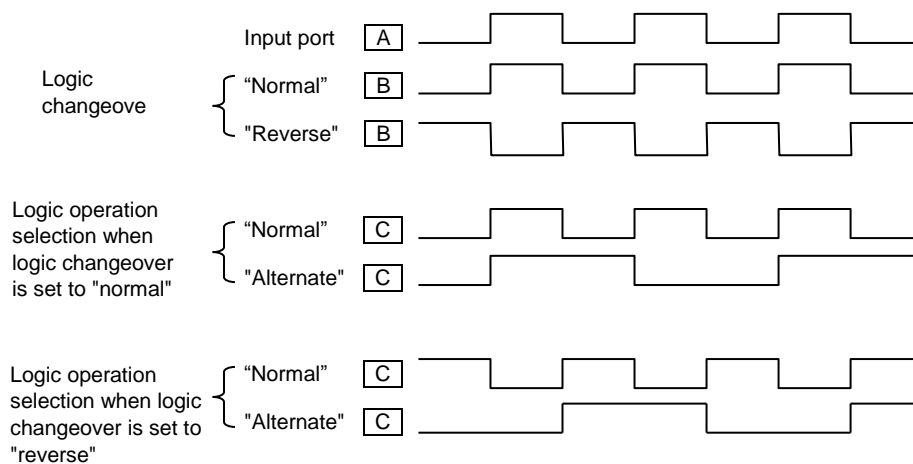

6. Block diagram (output control section)

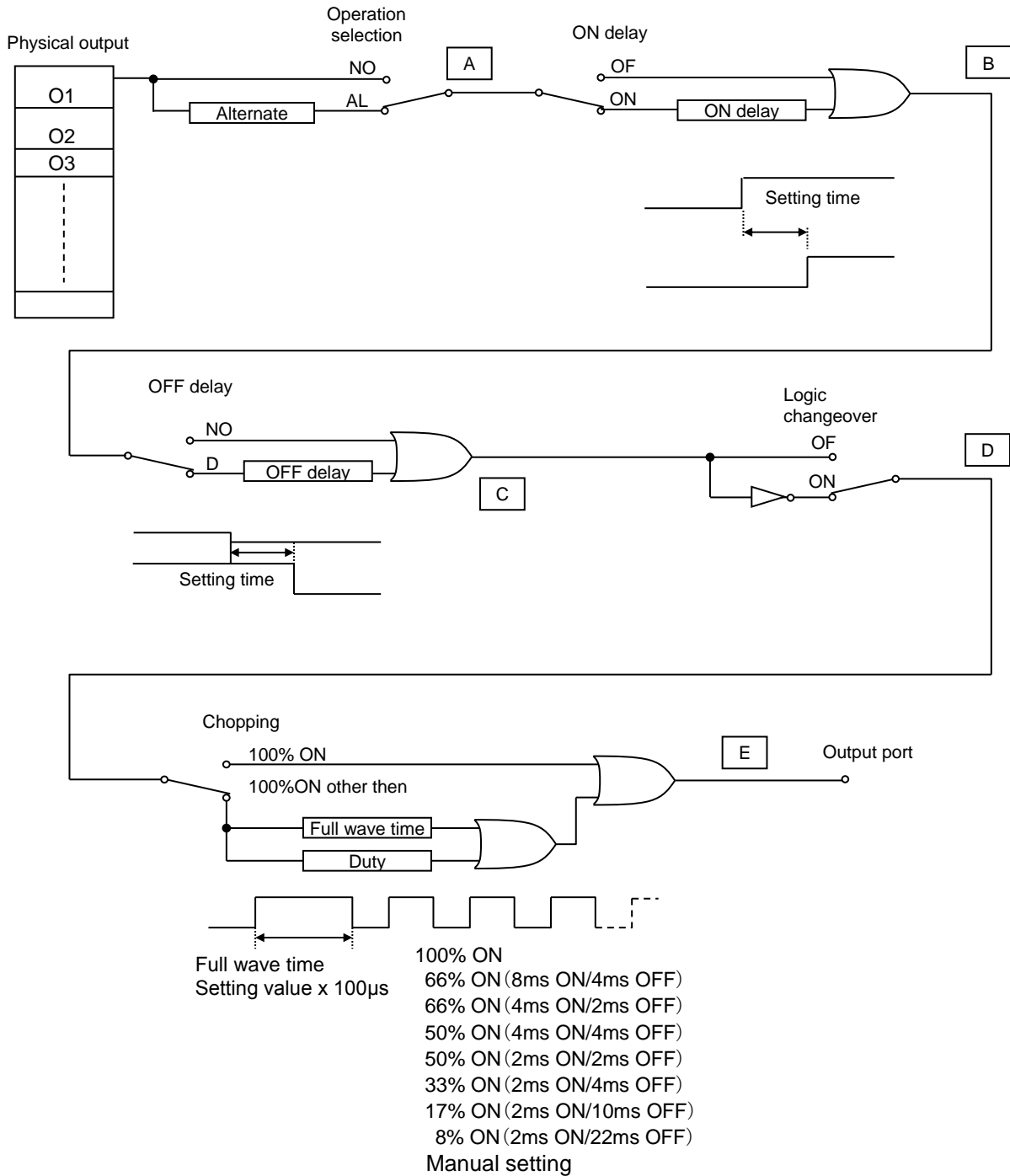

7. Explanation of operation (output control section)

The operation of the signal output from the physical output is selected and then the signal is connected to the output port E point.

A point Logic operation selection

(1)When "normal"(NO) is selected, the input waveform is connected.

(2)When "alternate"(AL) is selected, the signal will alternately turn ON and OFF, turning ON at the first rising edge and OFF at the next rising edge.

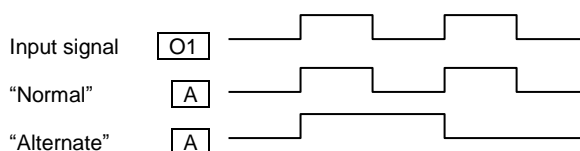

B point ON delay setting

- (1)When "invalid" is selected, the same signal as the A point will be output to the B point.
- (2)When "valid" is selected, the waveform will rise after the {set value x 100μs} time (*1) set with the A point input waveform. (ON delay)

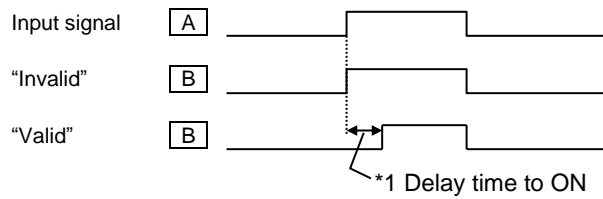

C point OFF delay setting

- (1)When "invalid" is selected, the same signal as the B point will be output to the C point.
- (2)When "valid" is selected, the ON time will be delayed by the {set value x 100μs} time (*2) set with the B point input waveform.

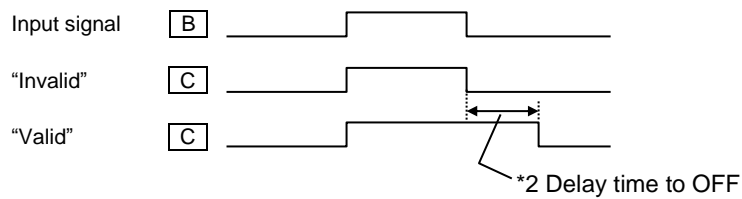

D point Logic setting

- (1)When "normal" is selected, the C point signal will be output to the D point without any changes.
- (2)When "reverse" is selected, D point signal will be reversing signal of the C point signal.

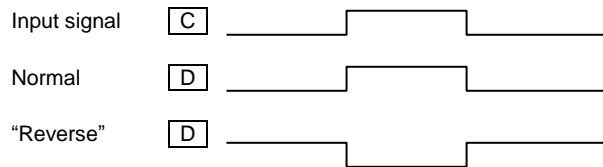

E point Chopping setting

- (1) When [100%ON] is set, there is no change, and input signal of D point is output to E point.
- (2) When other than [100%ON] is set, output of E point is on while {setting time x 100 us}. Afterwards the output becomes square wave according to duty ratio setting.

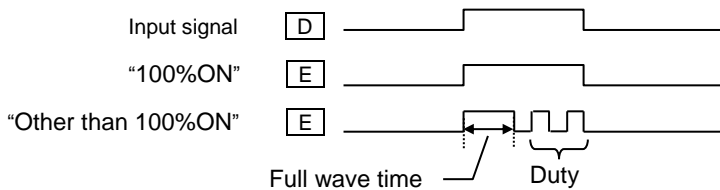

- 100% ON
- 66% ON (8ms ON/4ms OFF)
- 66% ON (4ms ON/2ms OFF)
- 50% ON (4ms ON/4ms OFF)
- 50% ON (2ms ON/2ms OFF)
- 33% ON (2ms ON/4ms OFF)
- 17% ON (2ms ON/10ms OFF)
- 8% ON (2ms ON/22ms OFF)
- Manual setting

[9] Input / Output signal

1. Input signal setting table

Code	Function	Specifications
FSP	Clamp all step ON signal	Whenever FSP input is on, clamp output [1],[2],[3],[4] turned on one by one. However, when [Program mode > Clamp output > number of effective clamp (FN)] is set to 1, FSP input is ineffective.
FSM	Clamp all step OFF signal	Whenever FSM input is on, clamp output [4],[3],[2],[1] turned off one by one. However, when [Program mode > Clamp output > number of effective clamp (FN)] is set to 1, FSM input is ineffective.
IFR	All clamp output clear signal	If IFR signal is on, all clamp outputs are turned off.
A2F	Pneumatic two-step clamp switch input signal	Whenever A2F input is on, following operation (1), (2), (3) is repeated. This signal is effective when [Program mode > Setting for Pneumatic two-step clamp (AF2)] is on. <div style="border: 1px solid black; padding: 5px; margin: 5px 0;"> (1) When A2F input is on first time, AFL output is turned on. (2) When A2F input is on second time, AFH output is turned on. (3) When A2F input is on third time, AFE output is turned on. </div>
IF1 to IF4	Clamp input signal 1 to 4	When IF1 input is on, OF1 output is turned on. When IF1 input is on again, OF1 output is turned off. (same from IF2 to IF4)
F1C to F4C	Clamp output prohibition signal 1 to 4	When F1C input is on, OF1 output is prohibited. (same from F2C to F4C)
OFC	All clamp output cancel signal	When OFC input is on, OF1 to OF4 outputs are prohibited.
WC	Wiper output cancel signal	When WC input is on, W output is prohibited.
TC	Trimmer output cancel signal	When TC input is on, Thread trimmer sequence output T, L and W-is prohibited.
S6	Thread trimming protection signal	When S6 input is on while machine is driving, the machine is stopped and when S6 input is off, the machine start driving again. When S6 input is on while thread trimming operation, machine is stopped after trimming.
HPC	Home positioning prohibition signal	When HPC is ON, home returning operation by the home positioning key or HP signal is prohibited.
THS	Upper thread sensor input signal	When setting of [Program mode > Needle thread breaking sensor ON/OFF] is on, the signal can be used for thread breakage detection input.
ARS	Less pressure detection signal	When ARS input is on, all operation is interrupted, and error [E-3108] is displayed. (Returns by power supply re-turning on)
IO0 to IOF	General purpose input 0 to F	When IO0 input is on, OT0 output is turned on at the same time. (same from IO1 to IOF)
NO	No operation signal	Anything does not operate, if NO input is turned on.
SRT	Start signal	When SRT input is on, sewing operation is started. However, when clamp output is turned off, this signal is invalid.
HP	Home position returning signal	When HP input is on, home position returning operation is executed. However, please note there is a timing that becomes invalid, for example while machine is running.
PF	Presser foot signal	When PF input is on, The presser foot will return to home position. When PF input is on again, presser foot goes to down position.
JGP	JOG plus signal	When JGP input is on, XY table is moved in positive direction according to the pattern.
JGM	JOG minus signal	When JGM input is on, XY table is moved in negative direction according to the pattern.
STP	Halt signal	When STP input is on, machine is stopped.
BC	Fixed angle (rotation/reverse rotation) signal	To confirm the needle thrust position, the needle is stopped just before the sewing material. Whenever BC input is ON, operation of [rotation] -> [reverse rotation] -> [rotation] is repeated. When the start switch is on afterwards, following sewing operation is started. However, if the following data is non stitch feed, the message [M-020] is appeared, in this case please move the needle to up position and re-turning on the start switch.
CCL	Counter clear signal	When CCL input is on, UP/DOWN counter is cleared.
SRC	Start cancel signal	When SRC input is on, sewing operation with Stringhalt is prohibited.
CCU	Up counter clear signal	When CCU input is on, UP counter is cleared.

< sequel to INPUT SIGNAL >

Code	Function	Specifications
CCD	Down counter clear signal	When CCD input is on, DOWN counter is cleared.
UAD	Up counter addition signal	When UAD input is on, 1 is added to UP counter
UDC	Up counter subtraction signal	When UDC input is on, 1 is subtracted from UP counter
DAD	Down counter addition signal	When DAD input is on, 1 is added to DOWN counter
DDC	Down counter subtraction signal	When DDC input is on, 1 is subtracted from DOWN counter
KNK	Signal that invalidates MENU key	When KNK is on, "MENU" key becomes invalid.
RNK	Signal that invalidates "pattern read" key	When RNK is on, "pattern read" key becomes invalid.
WNK	Signal that invalidates "pattern write" key	When WNK is on, "pattern write" key becomes invalid.
INK	Signal that invalidates "teaching input" key	When INK is on, "teaching input" key becomes invalid.
MNK	Signal that invalidates "teaching modification" key	When MNK is on, "teaching modification" key becomes invalid.
CNK	Signal that invalidates "teaching conversion" key	When CNK is on, "teaching conversion" key becomes invalid.
PNK	Signal that invalidates "program mode" key	When PNK is on, "program mode" key becomes invalid.
NNK	Signal that invalidates "IN/OUT setting" key	When NNK is on, "IN/OUT setting" key becomes invalid.
FNK	Signal that invalidates "function mode" key	When FNK is on, "function mode" key becomes invalid.
SNK	Signal that invalidates "speed" key	When SNK is on, "speed" key becomes invalid.
HNK	Signal that invalidates "PF height setting" icon	When HNK is on, "PF height setting" key becomes invalid.
DHK	Signal that invalidates "digital tension gauge" icon	When DKK is on, "digital tension gauge" key becomes invalid.
ENK	Signal that invalidates "easy setting" icon	When ENK is on, "easy setting" key becomes invalid.
P3NK	Signal that invalidates "standard screen 3" icon	When P3NK is on, "standard screen 3" (FF-stitch) key becomes invalid.
P01	Pattern number switch signal +1	When P01 is on, pattern data number is switch to 1001 (1000 + 1).
P02	Pattern number switch signal +2	When P02 is on, pattern data number is switch to 1002 (1000 + 2).
P04	Pattern number switch signal +4	When P04 is on, pattern data number is switch to 1004 (1000 + 4).
P08	Pattern number switch signal +8	When P08 is on, pattern data number is switch to 1008 (1000 + 8).
P16	Pattern number switch signal +16	When P16 is on, pattern data number is switch to 1016 (1000 + 16).
P32	Pattern number switch signal +32	<p>When P32 is on, pattern data number is switch to 1032 (1000 + 32).</p> <div style="border: 1px solid black; padding: 10px; margin: 10px 0;"> <p>< When you want to change to other patterned numbers ></p> <p>ex.1) pattern number to 1003 turns on P01 input and P02 input $P01(+1) + P02(+2) + 1000 = 1003$</p> <p>ex.1) pattern number to 1011 turns on P01, P02 and P08 input $P01(+1) + P02(+2) + P08(+8) + 1000 = 1011$</p> </div> <p>*Pattern number can be changed within the range from 1000 to 1063. *P01,P02,P04,P08,P16,P32 is effective when [Pattern select function by external signal(APC)] has been set to ON. *Pattern number is able to set to 1000,2000,3000,4000 by program mode "POF".</p>

< sequel to INPUT SIGNAL >

Code	Function	Specifications
HES	Machine head tilting detection signal	When HES input is on, message [M-038] is displayed.
SP0 to SP9	Speed dial signal	Speed dial value is switched to 0 to 9.
SPU	Speed up signal	Speed dial value is increased +1.
SPD	Speed down signal	Speed dial value is decreased -1.
CK1	Cassette jig sensor 1 signal	When CK1 and CK2 inputs is on, OF1 output turn on.
CK2	Cassette jig sensor 2 signal	*CK1 and CK2 is effective when [Cassette jig function ON/OFF (CHK)] and [Cassette jig sensor ON/OFF (CSN)] has been sets to ON.
BCDR	Barcode reading input signal	When input BCDR is turned ON, the pattern can be read with a barcode. This signal is effective when Program mode [Communication (UBCT)] is OFF.
DFCR	Input signal of material Thickness detection clear	Material thickness detection OK Output signal (DFOK), material thickness detection NG output signal (DPNG, DNNG) are turned OFF.
SKCR	Input signal of abnormal stitch detection clear	Turn off abnormality stitch detection OK output signal (SKOK) and abnormality stitch detection NG output signal (SKNG).
S2CR	Input signal of abnormal stitch detection 2 clear	Turn off abnormality stitch detection 2 OK output signal (S2OK) and abnormality stitch detection 2 NG output signal (S2NG).

2. Output signal setting table

Code	Function	Specifications
OT0 to OTF	Virtual output 0 to F	When IO0 is on, OT0 output at the same time (same from OT1 to OTF)
FN1 to FNH	Function code output 1 to H	When FUN1 code is read while sewing operation, FN1 output is reversed. (same from FN2 to FNH)
OF1 to OF4	Clamp output 1 to 4	When IF1 is on, OF1 output is reversed (same OF2 to OF4)
NO	[NO]output	Nothing is done
T	Trimmer output	Trimming operation is done
L	Thread tension release output	Thread tension release operation is done
W	Wiper output	Wiper operation is done
PF	Presser foot output	Presser foot operation is done
AFL	Pneumatic two-step switch clamp low pressure output	When A2F input is on first time, AFL output is turned on. Setting is effective when [Program mode > Clamp > Pneumatic two-step switch clamp ON/OFF (AF2)] is on.
AFH	Pneumatic two-step switch clamp high pressure output	When A2F input is on second time, AFH output is turned on. Setting is effective when [Program mode > Clamp > Pneumatic two-step switch clamp ON/OFF (AF2)] is on.
AFE	Pneumatic two-step switch clamp excess pressure release output	When A2F input is on third time, AFE output is turned on. Setting is effective when [Program mode > Clamp > Pneumatic two-step switch clamp ON/OFF (AF2)] is on.
DHP	Home position output	When XY table is stopped on the home position, DHP output is turned on.
D2H	Second home position output	When XY table is stopped on the second home position, D2H output is turned on.
RED	Preparation ready output	When the machine is ready state (when clamp output is on), RED output is turned on. When machine is start sewing, RED is turned off.
DSW	Sewing in progress output	When the machine is sewing, DSW output is turned on. When machine is stopping on the home position, DSW output is turned off.
SP	Sewing machine rotation start output	After non stitch feed, when the sewing machine start to rotate, SP output is turned on. When home positioning is executed, SP output is turned off.
TSE	Trimming start output	When trimming sequence (down position) is started, TSE output is turned on. When trimming sequence is finished (when all the outputs of T, L and W are turned off), TSE output is turned off.
END	Sewing completion output	When a sewing pattern operation is finished, END output is turned on. When the next sewing is started, END output is turned off.
DCS	Halt code output	When the halt code data (USTP, DSTP) is read while sewing, DCS output is turned on. When the machine restarts DCS output is turned off.
DST	Halt in progress output	When the machine is on halt state, DST output is turned on. When the machine restarts DST output is turned off. However, it is not output while stopping by the USTP code or the DSTP code.
HPO	Home returning in progress output	While the operation of home returning by the home positioning key or HP signal, HPO output is turned on.
ERR	Error output	When the error or message is displayed on the operation panel, ERR output is turned on.
CUE	Count up completion output	When the current value of up counter is reached at counter set value, CUE output signal is turned on. When the current value is cleared, CUE output is turned off.
CDE	Countdown completion output	When the current value of down counter is reached at 0, CDE output signal is turned on. When the current value is initialized, CDE output is turned off.
DTS	Halt in progress output after upper thread sensor detection	When the machine is on halt state with thread breakage, DTS output is turned on. When the machine restarts, DTS output is turned off.
DRT	Sewing machine rotation in progress output	While the machine is rotating, DRT output is turned on. (includes rotation in winding mode)
DN	Down position output	When the needle is down position, DN output is turned on.
CB	Buzzer output	While the buzzer in the operation panel is on, CB output is turned on. (including count up/countdown message display)
UP	Up position output	When the needle is up position, UP output is turned on.
PWR	Power on output	While power supply is on, PWR output signal is turned on.
PUS	Presser hoot home position output	While presser foot is on the home position, PUS output is turned on.

< sequel to OUTPUT SIGNAL >

Code	Function	Specifications
MSG	Message display output	When the message is displayed on the operation panel, MSG output is turned on.
OP1	Option output 1	Do not use
OP2	Option output 2	Do not use
SSW	Halt signal being on output	SSW is turned on during power supply is on. However, input signal STP turns on SSW is turned on with blinking.
MOV	Sending table's moving output signal	Turn on during XY table is moving.
OIL1	Oil lubrication output 1	When [OILV] setting is ON, OIL1 is output. Oil lubricate timing set by [OL1C] and [OL1T].
OIL2	Oil lubrication output 12	When [OILV] setting is ON, OIL2 is output. Oil lubricate timing set by [OL2C] and [OL2T].
SKAR	Air output for the abnormal stitch detection sensor	During automatic sewing, air for stitch abnormality detection is output. This signal is effective when Program mode [the stitch abnormality detection (SKCF)] or [the stitch abnormality detection 2 (S2CF)] is on.
SKCH	Output that is judging the abnormal stitch detection	SKCH output turns ON when operating checking about abnormality stitch. This signal is effective when Program mode [the stitch abnormality detection (SKCF)] is on.
SKTS	Test output of the abnormal stitch detection	When the sensor turns ON at the angle at which the stitch abnormality is judged, a test signal is output. This signal is effective when Program mode [the stitch abnormality detection (SKCF)] is on.
BDRD	Output where barcode pattern reading is completed	When reading the pattern number with the barcode it will be output. When sewing is started, the output turns OFF.
PKYC	Output where barcode pattern reading is waiting	When the bar code is ready to read the pattern number, it will be output. (PKY = ON and Pattern update incomplete)
SKNG	Abnormal stitch detection NG output	SKNG output turns ON when there are suspect of abnormality stitch. This signal is effective when Program mode [the stitch abnormality detection (SKCF)] is on.
SKOK	Abnormal stitch detection OK output	SKOK output turns ON When sewing is completed with no suspected abnormal stitch detected. This signal is effective when Program mode [the stitch abnormality detection (SKCF)] is on.
DPNG	Thickness detection NG(+side) output	DPNG output turns ON when material thickness is thicker than "Thickness setting parameter" at the thickness detection (DFTH) of sewing material.
DNNG	Thickness detection NG(-side) output	DNNG output turns ON when material thickness is thinner than "thickness setting parameter" at the thickness detection (DFTH) of sewing material.
DFOK	Thickness detection OK output	DFOK output turns ON when material thickness is within margin of error about "thickness setting parameter" at the thickness detection (DFTH) of sewing material.
ANT0	Analog input 0 judgement output	ANT 0 output turns ON when the input voltage of CON 10 "analog input 0" on the I / F board is greater than or equal to the program mode ANT 0 [threshold value setting of analog input 0] setting value
ANT1	Analog input 1 judgement output	ANT 1 output turns ON when the input voltage of CON 10 "analog input 1" on the I / F board is greater than or equal to the program mode ANT 1 [threshold value setting of analog input 1] setting value
S2NG	Abnormal stitch detection 2 NG output	S2NG output turns ON when there are suspect of abnormality stitch. This signal is effective when Program mode [the stitch abnormality detection 2 (S2CF)] is on.
S2OK	Abnormal stitch detection 2 OK output	S2OK output turns ON When sewing is completed with no suspected abnormal stitch 2 detected. This signal is effective when Program mode [the stitch abnormality detection 2 (S2CF)] is on.
S2CH	Angle for judgement on Abnormal stitch detection 2 output	S2CH output turns ON when operating checking about abnormality stitch. This signal is effective when Program mode [the stitch abnormality detection 2 (S2CF)] is on.

[10] What happened? Could it be an error?

When an error occurs, the error code and corresponding message appear on the operation panel. Take a corrective action in accordance with the message. This section describes the errors and others that do not appear on the operation panel.

[Case1]

Nothing appears on the operation panel when you turn the power switch ON.
“Both the front panel green (power) and red (warning) LEDs are off.”

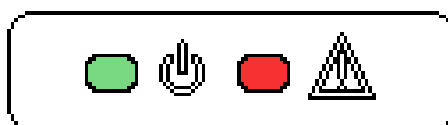

[Checking Items and Corrective Actions]

Is the power switch definitely turned ON?

- Check the power supply connection and turn ON the power switch again.

Is the power supply connector fully connected?

- Check the power supply connector connection, contact state and others, and then turn ON the power switch again.

Refer to “section [13].”

Is there a blown fuse in the control box?

- Replace the blown fuse with a fuse of identical capacity.

Refer to page [2] - 2.

Is a harness inside the control box disconnected?

- Check the connections of the harnesses inside the control box, and turn ON the power switch again.

Refer to “section [16].”

- Be sure to turn off the power when checking.

[Case2]

Though you turn the power switch ON and a screen appears on the operation panel, the screen display is incorrect.

[Checking Items and Corrective Actions]

Is the problem solved when you switch the screen or turn the power switch OFF and then ON again?

- Reinstall the system.

Refer to “[11] How to reinstalling the system”

- If you take a corrective action but no improvement is made, consult with your local representative.

[Case 3]

I press the foot pedal, but the machine does not run.

The message “MACHINE HEAD TILT WAS DETECTED” appears.

Or the message “START PROHIBIT SIGNAL BEING DETECTED” appears.

[Checking Items and Corrective Actions]

Is the machine tilted?

- Return the machine back to its proper state and try again.

- Check if the tilting sensor switch is damaged or disconnected.

Is the bobbin door open?

- Close the bobbin door.

- Check if the sensor switch of bobbin door is damaged or disconnected

Is the signal HES among the input signals changed?

- Check input customization.

[Case 4]

No screen appears on the operation panel when you turn the power switch ON. “The front panel red (warning) LED is off.”

[Checking Items and Corrective Actions]

The operation panel may be defective.

- Consult with your local representative.

[Case 5]

Error indication.

(The red LED on the front panel of the control unit is blinking)



[Red LED] Blink pattern

	☀ : ON - : OFF
Blink pattern 1	☀ - ☀ - ☀ - ☀ - ☀ - ☀ - ☀ - ☀ - ☀ - ☀ -
Blink pattern 2	☀ - - - ☀ - - - ☀ - - - ☀ - - -
Blink pattern 3	☀ - ☀ - ☀ - - - Repeat the next ☀ - ☀ - ☀ - - - ☀ - ☀ - ☀ - ☀ - ☀ - - -

Fig1

[Checking Items and Corrective Actions]

Is the front panel red (warning) LED showing Blink pattern 1? (Fig1)

- Installation error of control panel.

Please check the file and try again.

If the situation does not improve even after coping, there is a possibility that the CPU board is broken. consult with your local representative.

Is the front panel red (warning) LED showing Blink pattern 2? (Fig1)

- PAL communication error.

Please make sure that PAL is connected.

If you take a corrective action but no improvement is made, consult with your local representative.

Is the front panel red (warning) LED showing Blink pattern 3? (Fig1)

- It is a 12V error on the CPU board.

Is fuse 2.5A on the CPU board blown?

Replace the blown fuse with a fuse of identical capacity. (Refer to page [2]-2.)

Please be sure to replace the power supply in a disconnected state.

If you take a corrective action but no improvement is made, consult with your local representative.

[11] How to reinstalling the system

When it will reinstall the system for upgrade etc., please reinstall by according the following way by using USB flash drive.

It is necessary [PLKJ_SYSTEM] folder in the USB flash drive for installing.

Please check the following folder in the USB flash drive.

USB flash drive

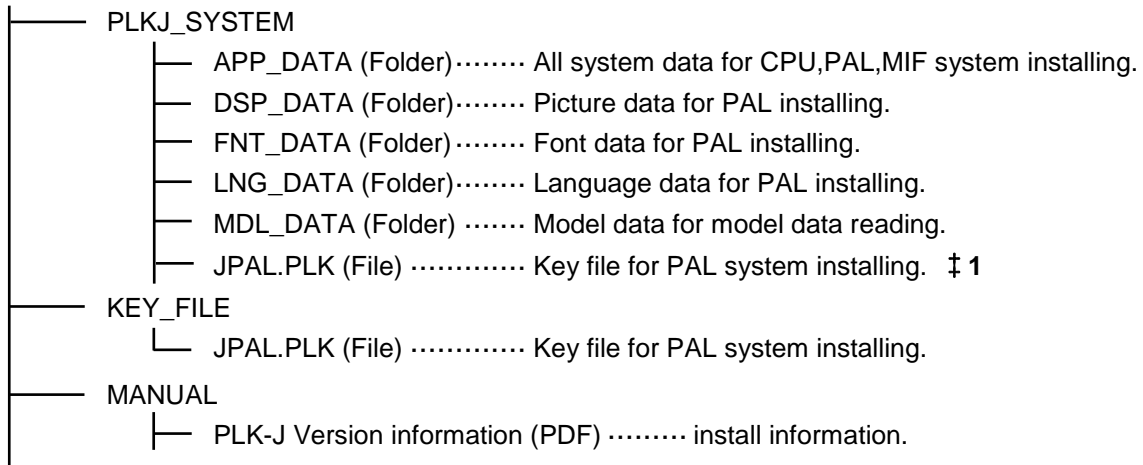

Device and installation place

Device	Version up	USB flash drive connection	Operation
Control box	System data · MAIN SYSTEM · DRIVE SYSTEM · FPGA MAIN · FPGA MIF	CON W (PAL)	Install button + Turn ON
	Model data "Setting of sewing machine for each model"	CON W (PAL)	Install button + Turn ON ‡ 2
PAL	System data · LCD SYSTEM	CON W (PAL)	Key file ‡ 1 + Turn ON
	Display data · LANGUAGE · LCD PICTURE · LCD FONT	CON W (PAL)	Touch the Mitsubishi logo after Turn ON
I/F board (MIF)	System data · MIF SYSTEM · PAGA MIF	CON U (MIF)	Turn ON

‡ 1: The "JPAL.PLK" key file will be deleted from the "PLKJ_SYSTEM" folder as the installation is completed, so copy it from the "KEY_FILE" folder and use it.

‡ 2: You can also initialize the sewing machine's settings without using USB flash drive.
Refer to page [11] – 6 "5.initialize settings".

1. Control box install

CPU system data upgrade

(1) Please insert USB flash drive to CON W connector on the operation panel.

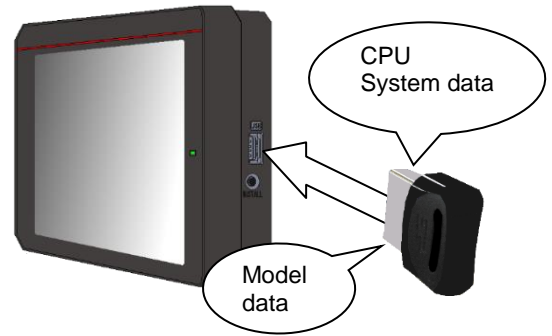

(2) Please hold down the install button and turn on the power.

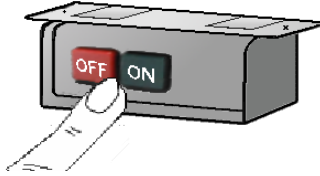

+



Please press install button for about 5 seconds from power on

(3) It will start to install, please wait a while still complete installing.

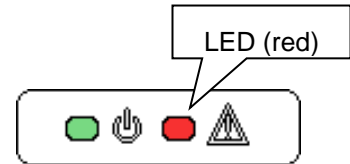

The red LED on the front of the control panel will be displayed during installation.



‡ If the red LED is blinking, the installation has failed. Check the "PLKJ_SYSTEM" folder inside the USB flash drive and try again.

(4) After the installation is completed, the "model set initialize function" screen will be displayed. If "SELECT", select model data from USB flash drive.

* Since it becomes the initial value, please refrain from the setting data when necessary.

▶ Please select the model name by   key.

And it is decided by push the  key.

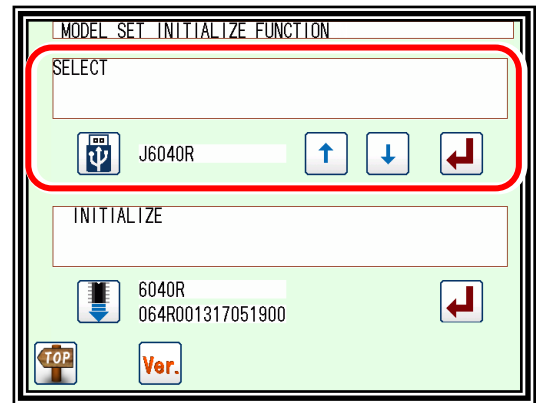

▶ Message is displayed.

Please turn off the power according to the message.

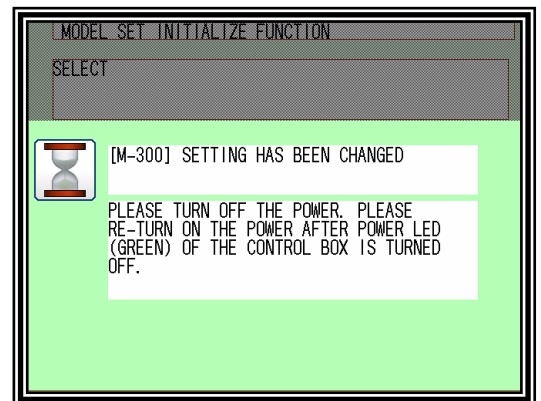

2. PAL install

① PAL system data upgrade

(1) Please put the key file [JPAL.PLK] into "PLKJ_SYSTEM" folder in USB flash drive.

Note ‡ If there is not the key file in "PLKJ_SYSTEM" folder, it is impossible to upgrade.

Notice ‡ The "JPAL.PLK" key file will be deleted as the installation is completed. To install again please copy from the "KEY FILE" folder and use it.

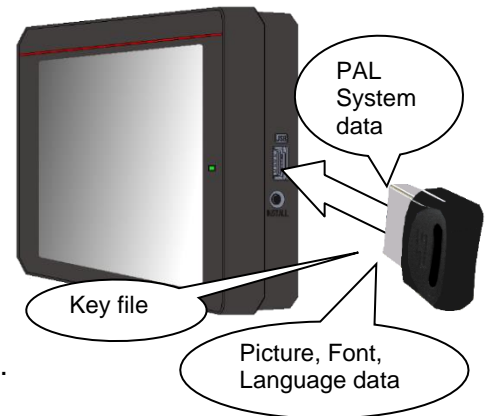

(2) Please insert USB flash drive to CON W connector on PAL.

(3) Turn the power on.

- ▶ The buzzer sounds eight times.
(If the buzzer does not sound, it will not install
Please check the key file.)
- ▶ Startup screen will appear after a while.

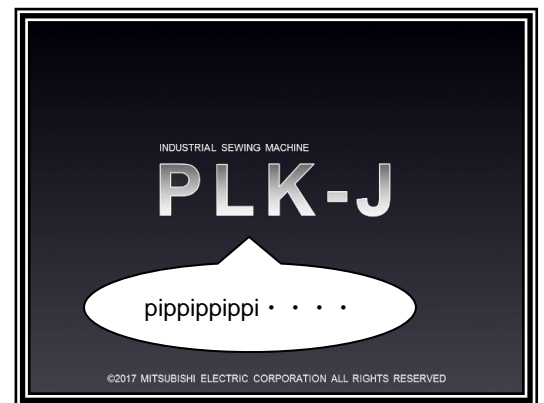

(4) Installing complete.

- ▶ Display is switched to standard screen after installing complete.

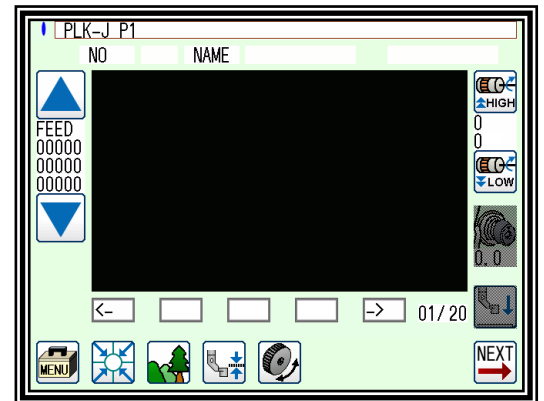

② Upgrade for Picture, Font, Language display data

(1) Please insert USB flash drive to CON W connector on PAL.

(2) Turn the power on.

- ▶ Please touch the Mitsubishi logo on the screen soon after display the startup screen.

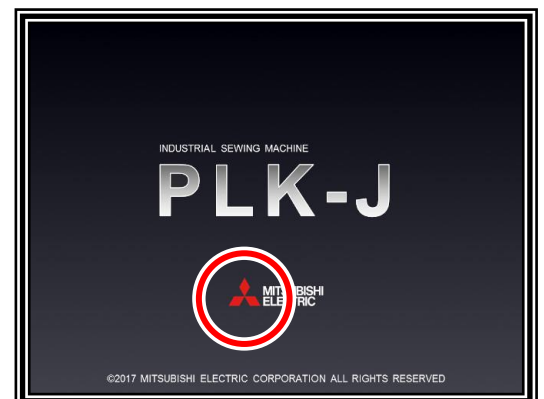

- ▶ It is appeared the install bar after sounds buzzer.

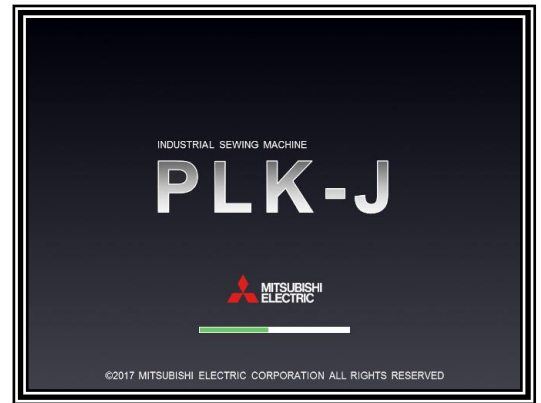

- ▶ In the case of a Successful installation, the install bar will turn blue.

Note If the red LED is blinking, the installation has failed. Check the "PLKJ_SYSTEM" folder inside the USB flash drive and try again.

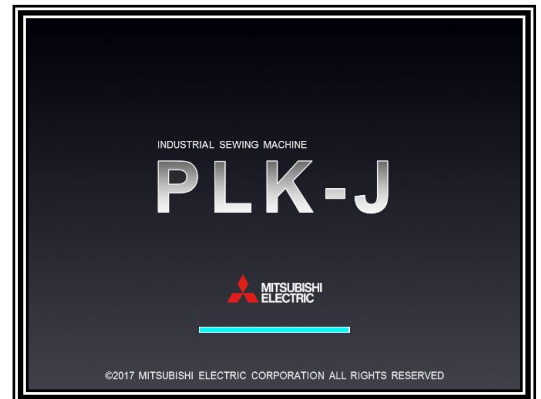

(3) Installing complete

- ▶ The buzzer beeps once and the installation is completed.
- ▶ Display is switched to standard screen after installing complete.

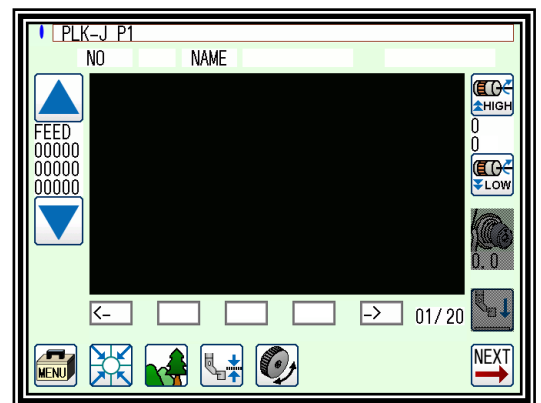

3. I/F board (MIF) Install

MIF system data upgrade

- (1) Please insert USB flash drive to CON U connector on PAL.

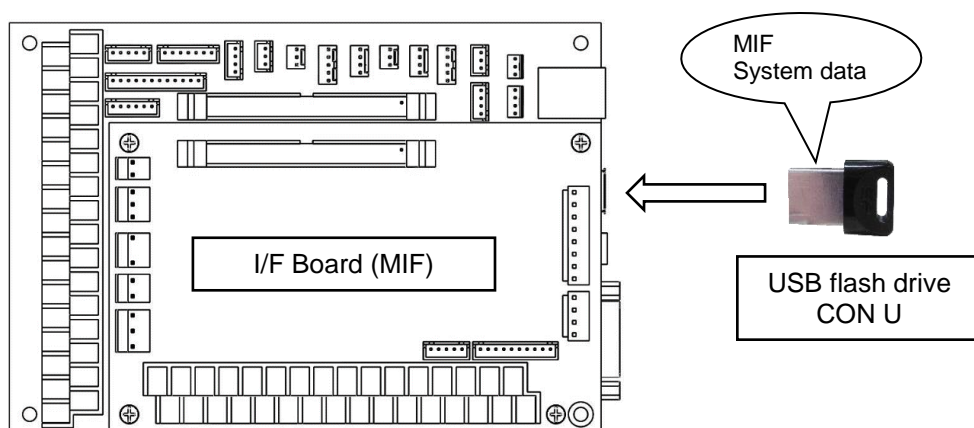

- (2) Turn the power on.

- ▶ It is started to install automatically, please wait a while at the startup screen.
- ▶ When the display is switched to standard screen, it become installing complete.

4. Confirm version information

Make sure the installed version is correct.

(1) Select function from PAL menu

▶ Press  to **Function**.

▶ Press  to display the version display function screen.

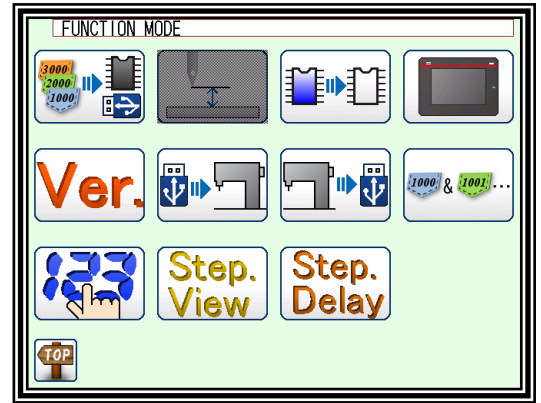

(2) Confirmation by the check function

Insert the USB flash drive containing the "PLKJ_SYSTEM" folder used for installation.

Compare the file in the USB flash drive with the software version inside the sewing machine.

▶ Press  to check the version.

If the software version is different, it will be displayed in reverse

※When USB flash drive is unconnected and pushes the  button, it is made all reversing display.

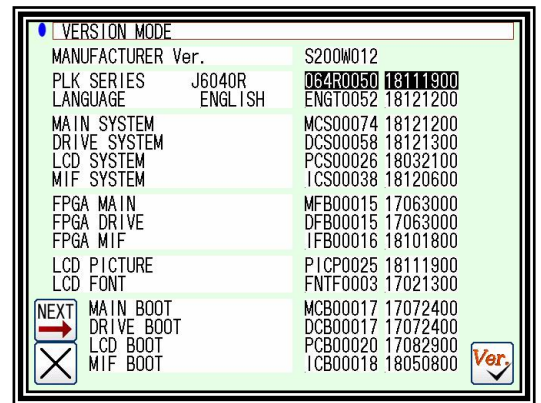

(3) Check with the **PLK-J Version information (PDF)** in the USB flash drive against the version display screen.

* PLK-J Version information (PDF) contains the software version at the time of shipment.

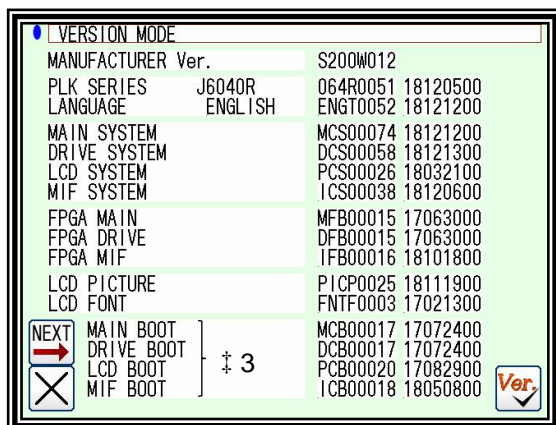

PAL screen

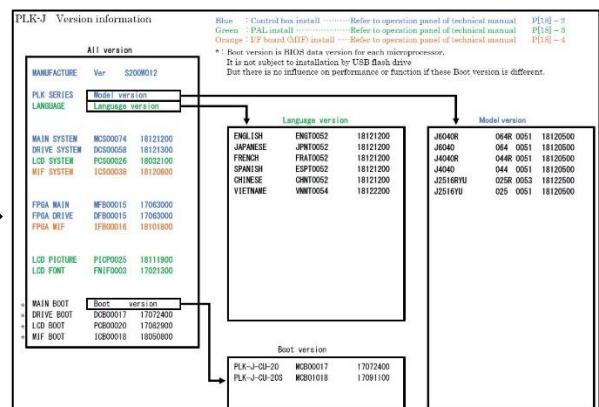

PLK-J Version information

(4) If there is a part that does not match the software version, please re-install the part.

Please refer to the table of P[11] -1 for the location updated by installation.

‡ 3: Boot version is BIOS data version for each microprocessor.

It is not subject to installation by USB flash drive

But there is no influence on performance or function if these Boot version is different.

5. Initialize settings

You can initialize the sewing machine settings without using USB flash drive.

Please hold down the install button and turn on the power.

Reset the setting of the sewing machine you are using to "Initialize" to the initial value.
"Initial setting value in internal memory"

▶ It decide by  key

▶ A message will be displayed, so please operate according to the message.

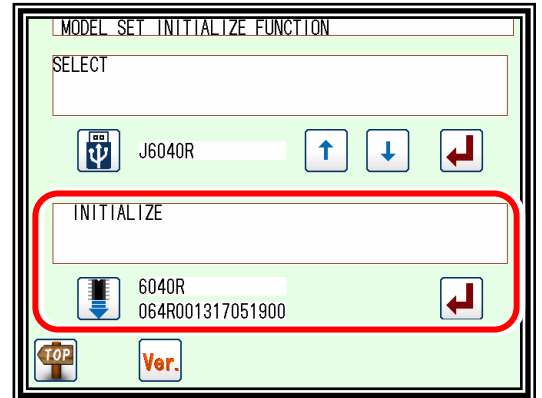

Note When returning to the standard screen without changing the initial value

When you press the  key, a message like the one on the right appears.

If you touch  key, it is possible to move standard screen without initialize.

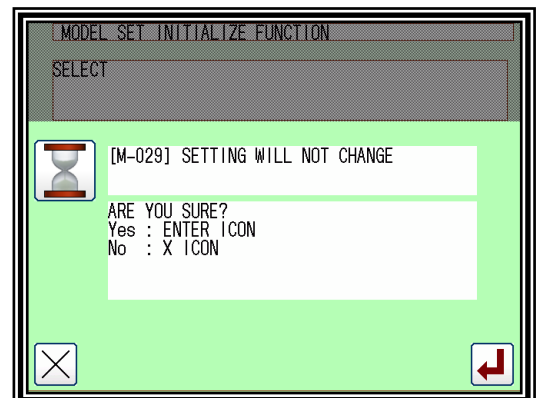

Note To erase internal memory, please use format.

Refer to the technical document for operation panel page [14] - 3 "Format".

[12] Several power supply

1. 3Ø AC200V - 240V 50/60Hz

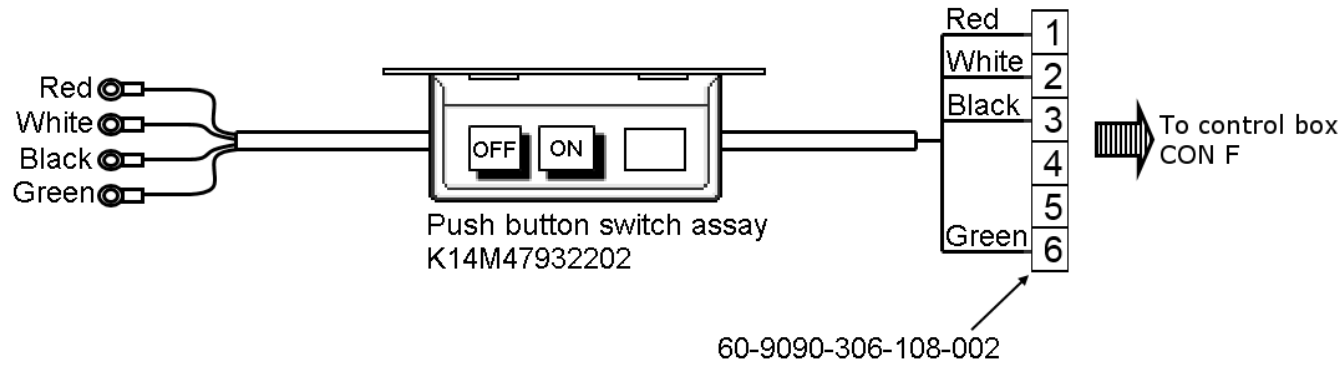

2. 1Ø AC200V - 240V 50/60Hz (Except Europe)

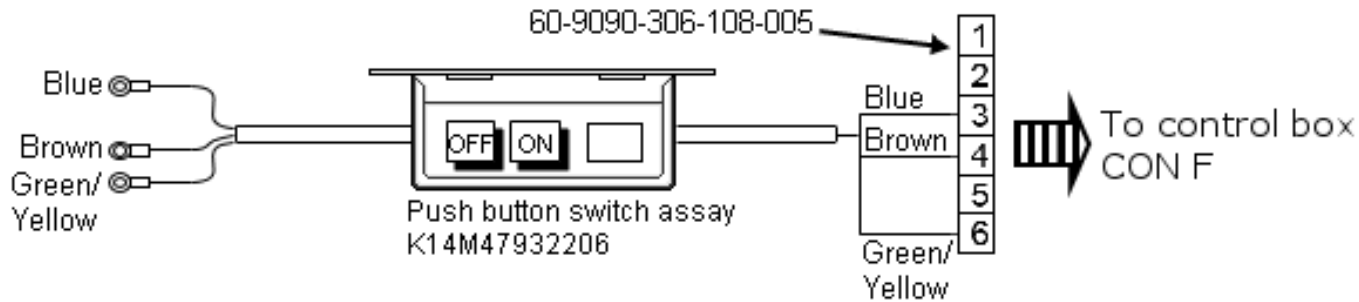

3. 3Ø AC380V - 415V 50/60Hz (Except Europe)

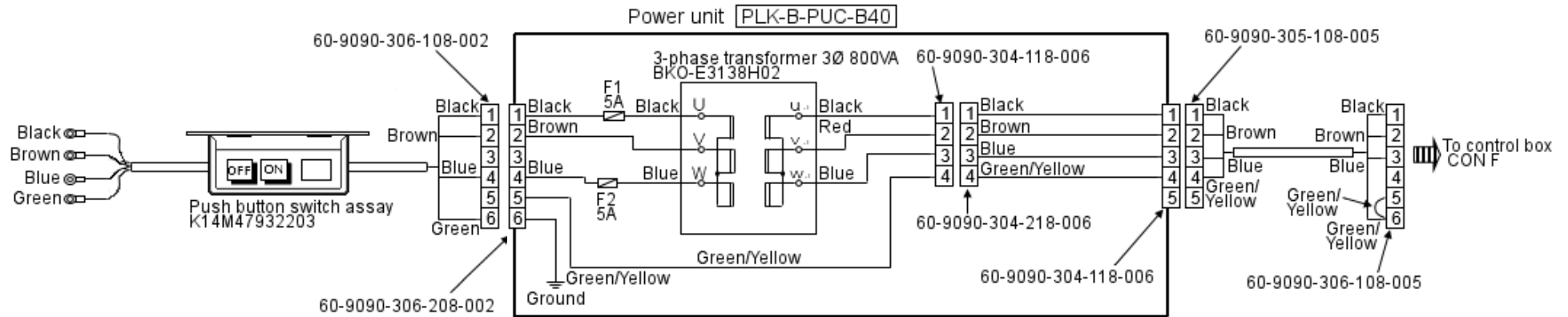

4. 1Ø AC200V - 240V 50/60Hz (Europe)

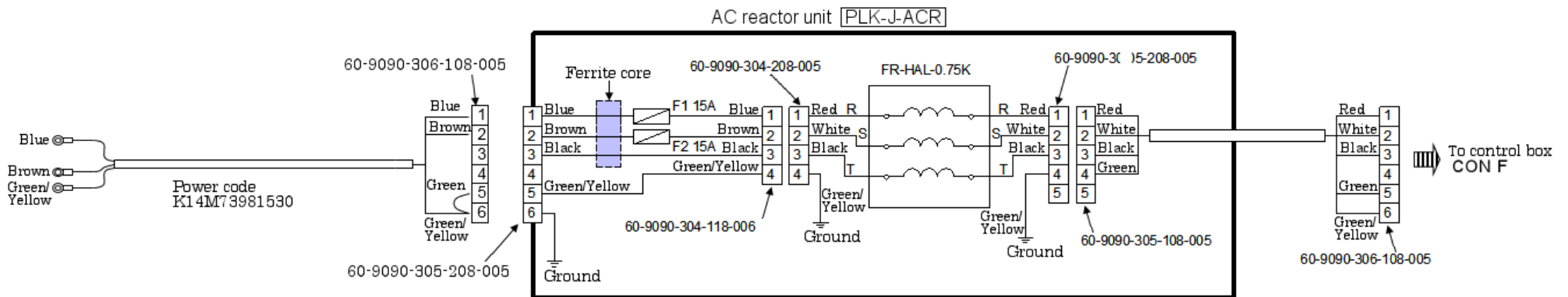

[13] Unit wiring diagram

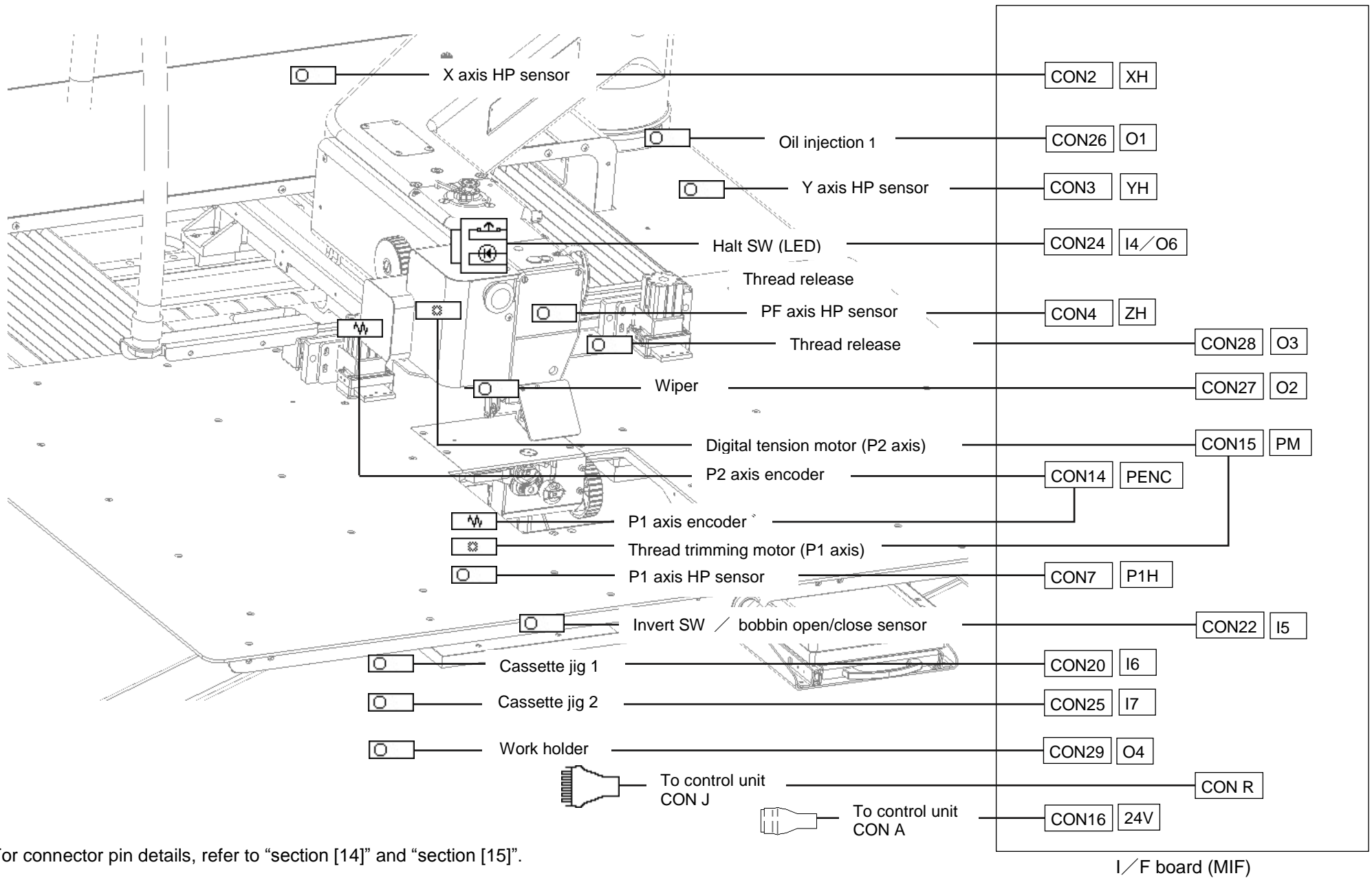

[13] - 1

■ For connector pin details, refer to “section [14]” and “section [15]”.

I/F unit in Back side of machine head

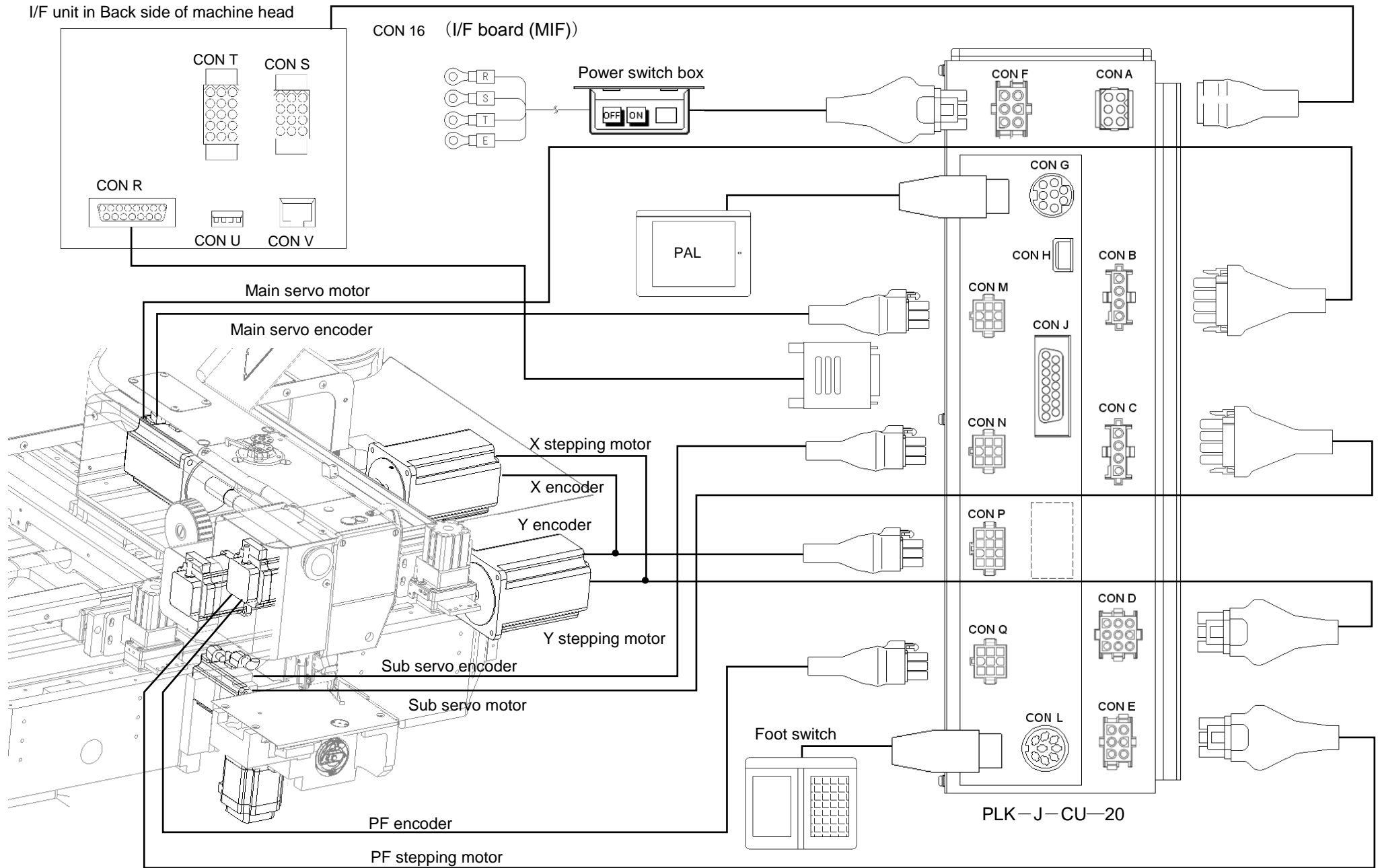

[14] Connectors layout

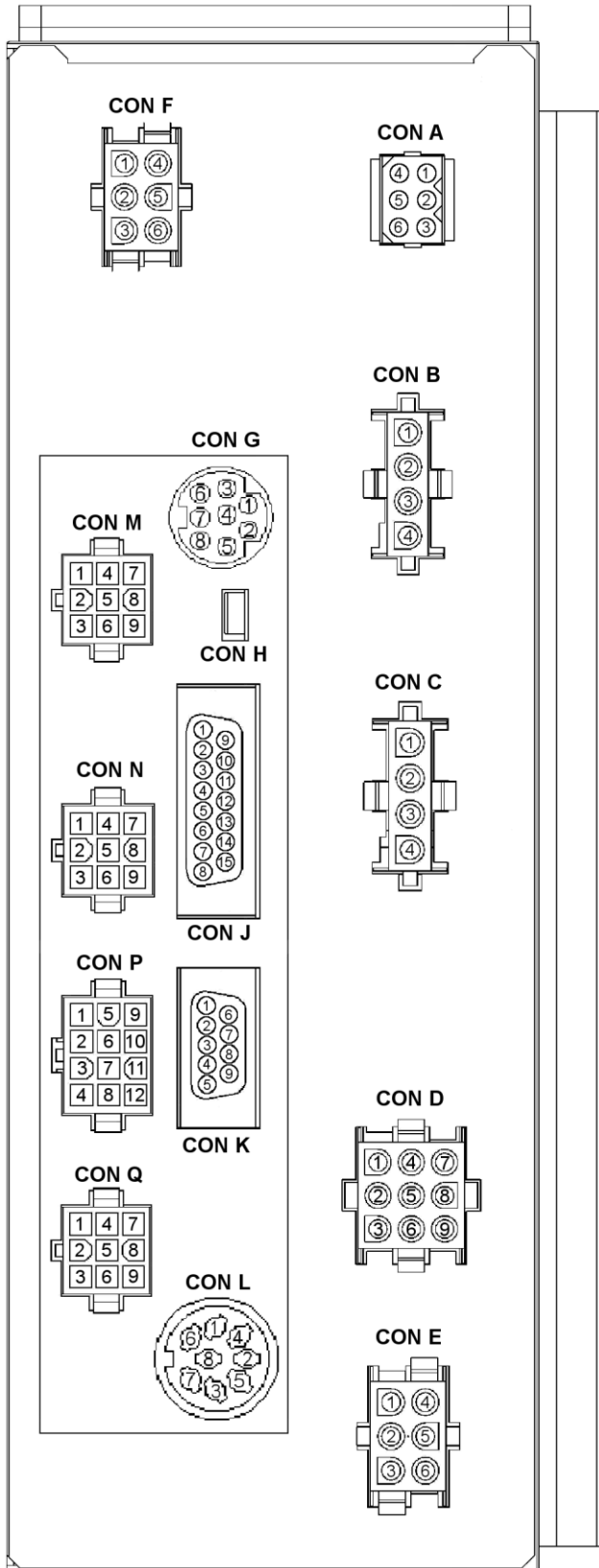

[front panel of the control box]

About CON H

Please only connect PC

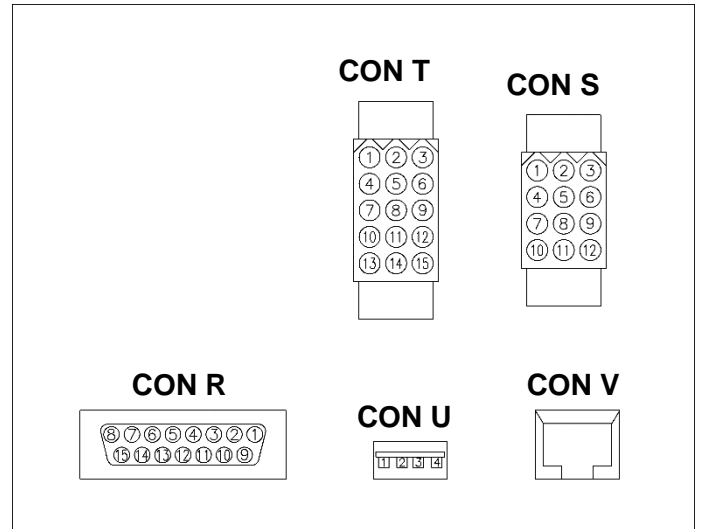

[I/F unit in Back side of machine head]

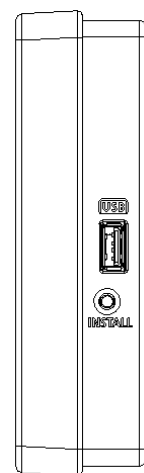

CON W
(USB connector)

INSTALL Button

[PAL]

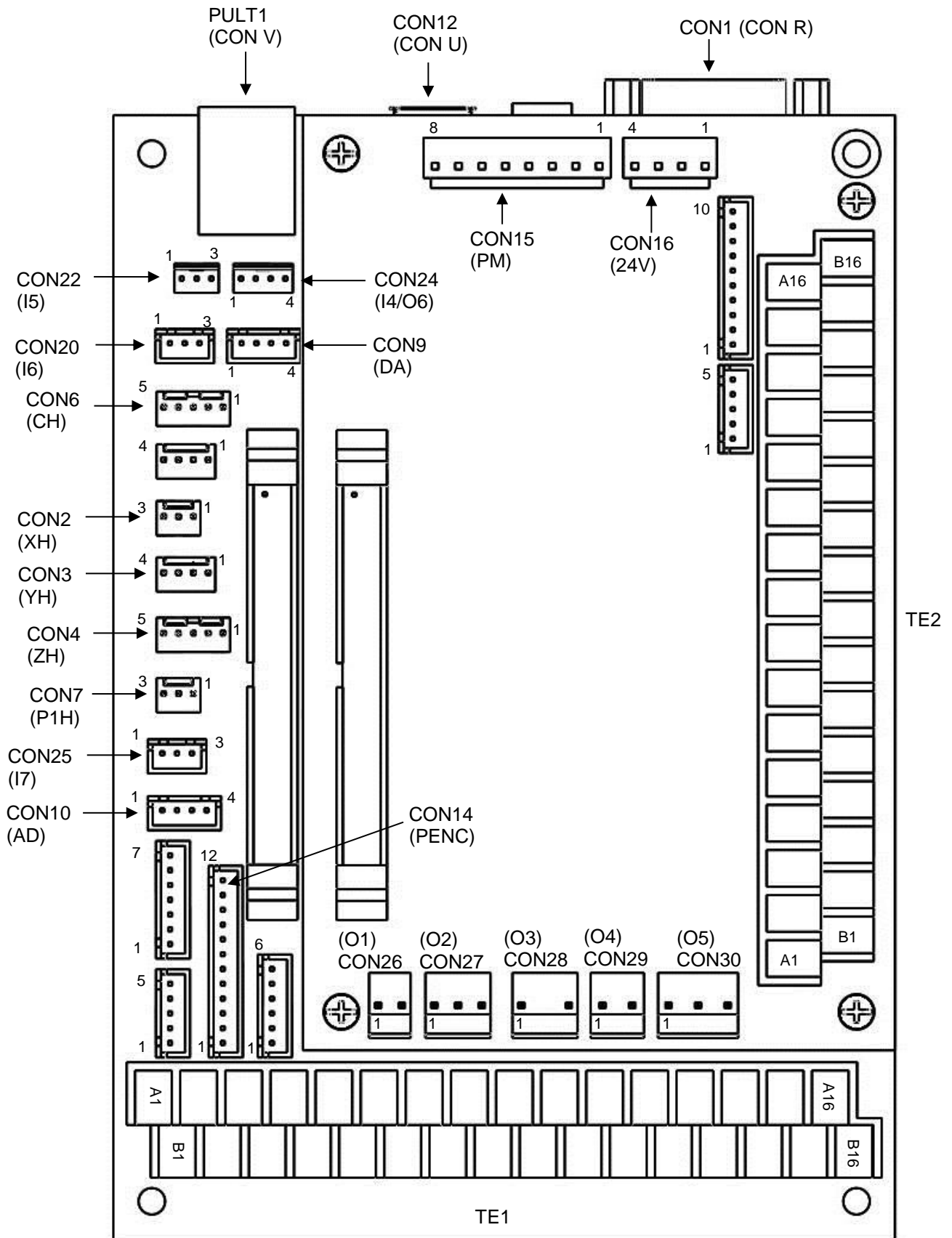

[I/F board (MIF)]

[15] Pin number of connectors

1. Back side of control box/sewing machine

CON A (I/F BOARD (power supply))

Signal	Pin No.
+24V	1
+24V	2
NC	3
GND	4
GND	5
FG	6

CON B (MAIN SERVO MOTOR)

signal	Pin No.
U	1
V	2
W	3
FG	4

CON C (SUB SERVO MOTOR)

Signal	Pin No.
U	1
V	2
W	3
FG	4

CON D (XY STEPPING MOTOR)

Signal	Pin No.
XA1	1
XA2	2
XB1	3
YA1	4
FG	5
XB2	6
YA2	7
YB1	8
YB2	9

CON E (PF STEPPING MOTOR)

Signal	Pin No.
ZA1	1
ZA2	2
NC	3
ZB1	4
ZB2	5
FG	6

CON F (POWER SUPPLY)

Signal	Pin No.
R	1
S	2
T	3
NC	4
FG	5
FG	6

CON G (LCD PANEL)

Signal	Pin No.
+12V	1
GND	2
TXD0	3
RXD0	4
INSTALL	5
VBUS	6
DP	7
DM	8

CON H (OPTION PORT (PC connection))

Signal	Pin No.
VBUS	1
DM	2
DP	3
NC	4
GND	5

‡ Please only connect PC

CON J (I/F BOARD (signal)) (same for CON R)

Signal	Pin No.
+12V	1
RXD0	2
TXD0	3
GND	4
+12V	5
RXD1	6
TXD1	7
GND	8
XHOME	9
YHOME	10
ZHOME	11
STP	12
UP	13
DN	14
CH	15

CON L (FOOT SWITCH)

Signal	Initial setting	Pin No.
+12V	+12V	1
I1	[SRT] Start input	2
I2	[IF1] Work holder output 1	3
VC1	do not use	4
GND	GND	5
GND	GND	6
I3	[IF2] Work holder output 2	7
GND	GND	8

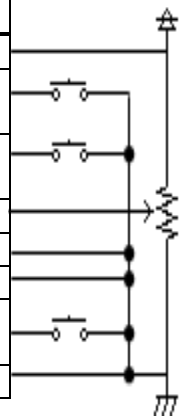

CON M (MAIN SERVO ENCODER)

Signal	Pin No.
1MR	1
1MRR	2
NC	3
1MX	4
1MXR	5
GND	6
+5V	7
GND	8
FG	9

CON N (SUB SERVO ENCODER)

Signal	Pin No.
2MR	1
2MRR	2
NC	3
2MX	4
2MXR	5
GND	6
+5V	7
GND	8
FG	9

CON P (XY ENCODER)

Signal	Pin No.
GND	1
+5V	2
GND	3
FG	4
XAN	5
XBN	6
YAN	7
YBN	8
XAP	9
XBP	10
YAP	11
YBP	12

CON Q (PF ENCODER)

Signal	Pin No.
ZAP	1
ZBP	2
+5V	3
ZAN	4
ZBN	5
GND	6
NC	7
NC	8
FG	9

CON S (OPTION INPUT)

Signal	Initial setting	Pin No.
+12V	+12V	1
I8	[NO] do not	2
GND	GND	3
+12V	+12V	4
I9	[NO] do not	5
GND	GND	6
+12V	+12V	7
IA	[NO] do not	8
GND	GND	9
+12V	+12V	10
IB	[NO] do not	11
GND	GND	12

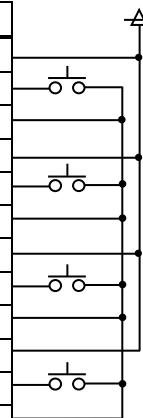

CON T (OPTION OUTPUT) (output for solenoid valve)

Signal	Initial setting	Pin No.
+24V	+24V	1
O7	[DSW] Sewing in progress output	2
GND	GND	3
+24V	+24V	4
O8	[SKAR] Air output for SKCF	5
GND	GND	6
+24V	+24V	7
O9	[NO] do not	8
GND	GND	9
+24V	+24V	10
OA	[NO] do not	11
GND	GND	12
+24V	+24V	13
OB	[NO] do not	14
GND	GND	15

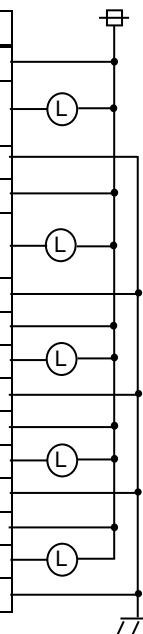

*Refer to page [14] - 6 for the ratings of solenoid valve

CON U ((USB connector) barcode reader)

Signal	Pin No.
VBUS	1
DP	2
DM	3
GND	4

‡ Please do not use to charge for the battery of electronic device.

CON V (LAN)

Signal	Pin No.
TD+	1
TD-	2
CT	3
GND	4
GND	5
CT	6
RD+	7
RD-	8

2. I/F BOARD (MIF)

(1) INPUT

CON2

Printed character	Signal		Pin No.
XH	GND	Ground	1
	XH	X axis home position detection	2
	D12V	DC12V Power supply	3

CON3

Printed character	Signal		Pin No.
YH	GND	Ground	1
	GND	Ground	2
	YH	Y axis home position detection	3
	D12V	DC12V Power supply	4

CON4

Printed character	Signal		Pin No.
ZH	GND	Ground	1
	GND	Ground	2
	GND	Ground	3
	ZH	PF axis home position detection	4
	D12V	DC12V Power supply	5

CON6

Printed character	Signal		Pin No.
CH	GND	Ground	1
	GND	Ground	2
	GND	Ground	3
	CH	Abnormal stitch detection sensor	4
	D12V	DC12V Power supply	5

CON7

Printed character	Signal		Pin No.
P1H	GND	Ground	1
	P1H	P1 axis home position sensor	2
	D12V	DC12V Power supply	3

CON10

Printed character	Signal		Pin No.
AD	DC12V	DC12V Power supply	1
	AN0	Analog input 0	2
	AN1	Analog input 1	3
	GND	Ground	4

CON14

Printed character	Signal		Pin No.
PENC	+5V	DC5V power supply	1
	+5V	DC5V power supply	2
	P1_AP	P1 axis encoder A	3
	P1_AN	P1 axis encoder A	4
	P1_BP	P1 axis encoder B	5
	P1_BN	P1 axis encoder B	6
	P2_AP	P2 axis encoder A	7
	P2_AN	P2 axis encoder A	8
	P2_BP	P2 axis encoder B	9
	P2_BN	P2 axis encoder B	10
	GND	Ground	11
GND	Ground	12	

CON16

Printed character	Signal		Pin No.
24V	+24V	DC24V power supply	1
	PGND	Ground	2
	A24V	Analog 24V Power supply	3
	AGND	Analog ground	4

CON20

Printed character	Signal		Pin No.
16	12V	DC12V Power supply	1
	I6	[CK1]Cassette Jig 1 sensor	2
	GND	Ground	3

CON22

Printed character	Signal		Pin No.
15	12V	DC12V Power supply	1
	I5	[HES] machine tilting detection input / Bobbin door open/close sensor	2
	GND	Ground	3

CON24

Printed character	Signal		Pin No.
I4/O6	I4	[STP] Halt SW	1
	GND	Ground	2
	12V	DC12V Power supply	3
	O6	[SSW]Halt stop output	4

CON25

Printed character	Signal		Pin No.
I7	12V	DC12V Power supply	1
	I7	[CK2] Cassette Jig 2 sensor	2
	GND	Ground	3

TE1

Printed character	Signal		Pin No.
TE1	IC	[NO] do not	A1
	ID	[NO] do not	A2
	IE	[NO] do not	A3
	IF	[NO] do not	A4
	IG	[NO] do not	A5
	IH	[NO] do not	A6
	II	[NO] do not	A7
	IJ	[NO] do not	A8
	IK	[NO] do not	A9
	IL	[NO] do not	A10
	IM	[NO] do not	A11
	IN	[NO] do not	A12
	IO	[NO] do not	A13
	IP	[NO] do not	A14
	IQ	[NO] do not	A15
	IR	[NO] do not	A16
TE1	12V	DC12V	B1
	GND	Ground	B2
	12V	DC12V	B3
	GND	Ground	B4
	12V	DC12V	B5
	GND	Ground	B6
	12V	DC12V	B7
	GND	Ground	B8
	12V	DC12V	B9
	GND	Ground	B10
	12V	DC12V	B11
	GND	Ground	B12
	12V	DC12V	B13
	GND	Ground	B14
	12V	DC12V	B15
	GND	Ground	B16

(2) OUTPUT

CON9

Printed character	Signal		Pin No.
DA	D12V	DC12V Power supply	1
	DA0	DA output 0	2
	DA1	DA output 1	3
	GND	Ground	4

CON30

Printed character	Signal		Pin No.
O5	O5	[OIL2] Oil lubrication output 2	1
	NC	—	2
	24V	DC24V Power supply	3

CON15

Printed character	Signal		Pin No.
PM	P2B1	P2 axis motor power B	1
	P2B2	P2 axis motor power B	2
	P2A1	P2 axis motor power A	3
	P1A2	P1 axis motor power A	4
	P1A1	P1 axis motor power A	5
	P2A2	P2 axis motor power A	6
	P1B1	P1 axis motor power B	7
	P1B2	P1 axis motor power B	8

TE2

Printed character	Signal		Pin No.
TE2	OC	[NO] do not	A1
	OD	[NO] do not	A2
	OE	[NO] do not	A3
	OF	[NO] do not	A4
	OG	[NO] do not	A5
	OH	[NO] do not	A6
	OI	[NO] do not	A7
	OJ	[NO] do not	A8
	OK	[NO] do not	A9
	OL	[NO] do not	A10
	OM	[NO] do not	A11
	ON	[NO] do not	A12
	OO	[NO] do not	A13
	OP	[NO] do not	A14
	OQ	[NO] do not	A15
	OR	[NO] do not	A16
E2	24V	DC24V	B1
	GND	Ground	B2
	24V	DC24V	B3
	GND	Ground	B4
	24V	DC24V	B5
	GND	Ground	B6
	24V	DC24V	B7
	GND	Ground	B8
	24V	DC24V	B9
	GND	Ground	B10
	24V	DC24V	B11
	GND	Ground	B12
	24V	DC24V	B13
	GND	Ground	B14
	24V	DC24V	B15
	GND	Ground	B16

CON26

Printed character	Signal		Pin No.
O1	O1	[OIL1] Oil lubrication output 1	1
	24V	DC24V Power supply	2

CON27

Printed character	Signal		Pin No.
O2	O2	[W] Wiper /Upper thread retention	1
	NC	—	2
	24V	DC24V Power supply	3

CON28

Printed character	Signal		Pin No.
O3	O3	[L] Thread release	1
	24V	DC24V Power supply	2

CON29

Printed character	Signal		Pin No.
O4	O4	[CK1] Cassette Jig 1 / [OF1] work holder output 1	1
	24V	DC24V Power supply	2

* When the error occurs, outputs are turned off. However, "O4" outputs. Do not turned off except overcurrent error situation.

(3) PAL (CON W) and MIF board (CON U) USB connector

Conditions of application

USB flash drive ……USB1.1 or USB2.0 or USB3.0 compatible USB flash drive

Barcode reader (MIF only)

We recommend using the attached USB flash drive. If you use a USB flash drive other than included, you may not be able to save or read normally.

Inapplicable devices

USB device requiring an external power supply (including Computer devices)

USB hard disk drive, keyboard, mouse

USB flash drive with fingerprint authentication function or with security function

USB flash drive with hub function

Media reader

USB device without data storage function

USB connecting device

	PAL CON W	MIF board CON U	Control box CON H
USB flash drive Standard 1.1、2.0、3.0 only	Yes	Yes	No
Barcode reader	No	Yes	No
PC	No	No	Yes
Other USB device	No	No	No

3. Ratings value of input /output

(1) Ratings value of the solenoid valve output

Power supply	Output	maximum ratings current	All output
DC24V	O1 to O2	2 total 0.5A or less	26 total 3.0A or less
DC24V	O3 to O5 O7 to OB	8 total 0.5A or less	
DC24V	OC to OJ	8 total 0.5A or less	
DC24V	OK to OR	8 total 0.5A or less	

(2) Output for display light or buzzer

Output	Printed character	Power	Maximum ratings current
O6	I4/O6	DC12V	0.1A or less

(3) Analog output

Output	Printed character	Power	Output voltage	Maximum ratings current
DA0	DA	DC12V	DC 0 to 10V	0.01A or less
DA1	DA	DC12V	DC 0 to 10V	0.01A or less

*Use the input resistance of the connection destination at 1kΩ or more.

Example of use

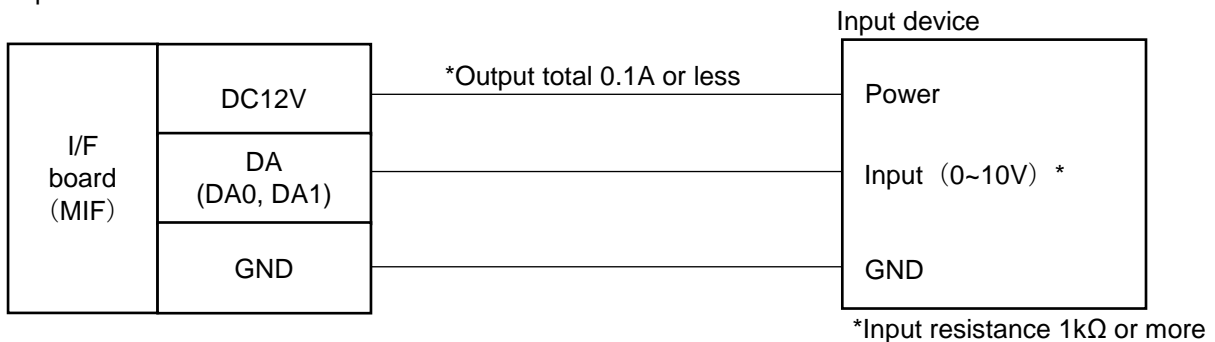

(4) Analog input

Output	Printed character	Power	Output voltage
AN0	AD	DC12V	DC 0 to 12V
AN1	AD	DC12V	DC 0 to 12V

Example of use

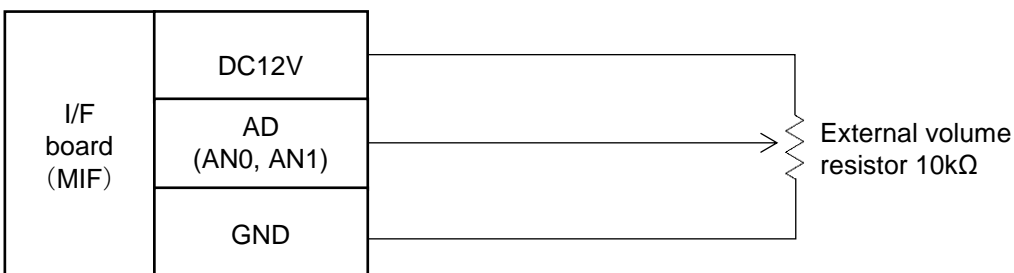

[16] Wiring diagram inside control box

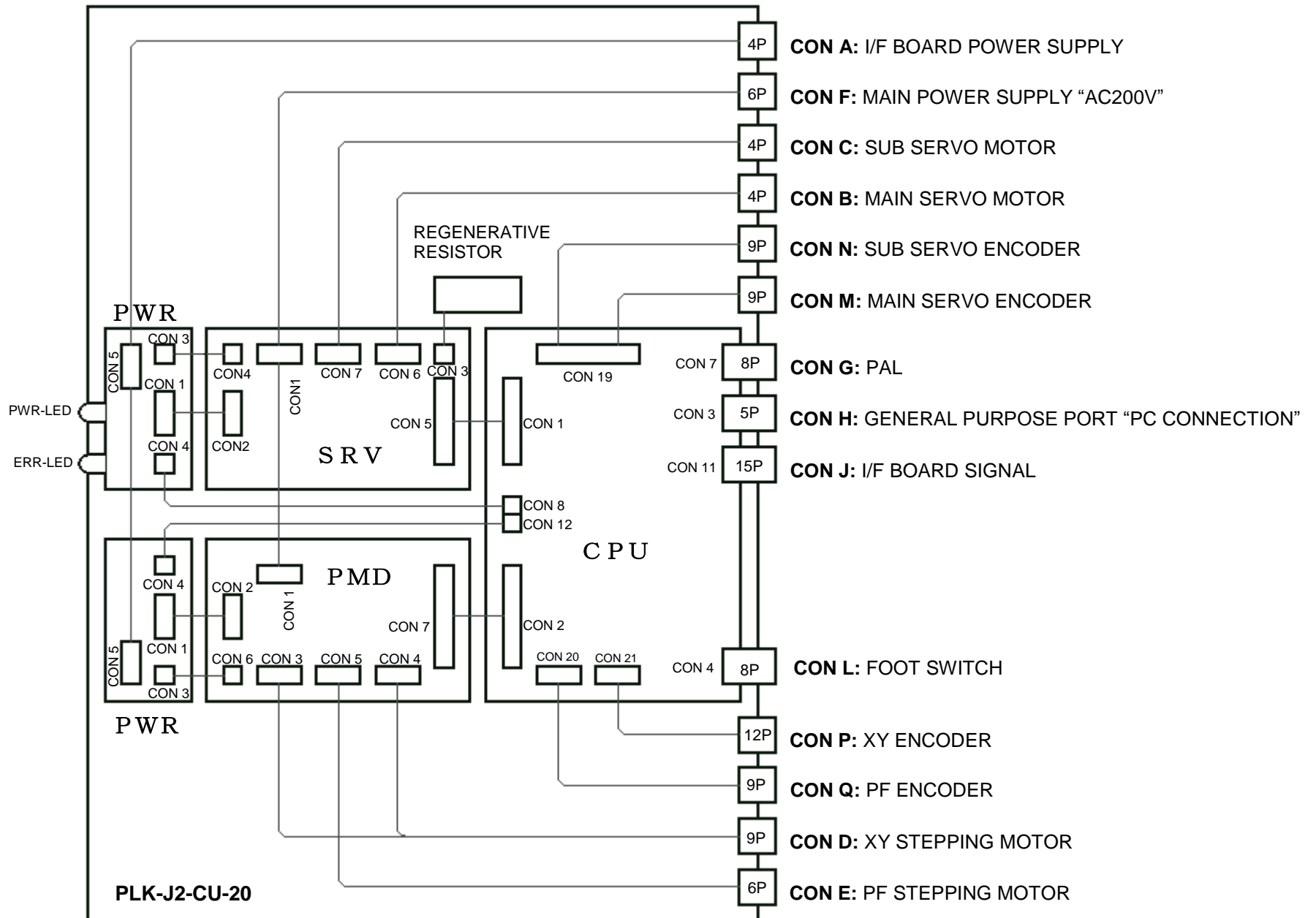

[17] Specifications

Power source		200 to 240V 50/60Hz Single phase or 3-phase	200 to 240V 50/60Hz Single phase (Europe)	380 to 415V 50/60Hz 3-phase
Specifications				
Power unit		-	-	PLK-B-PUC-B40
Noise filter unit		-	PLK-J-CE PLK-J-ACR	-
Main servo motor	Rated output	750W		
	Rated speed	3,000rpm		
Sub servo motor	Rated output	400W		
	Rated speed	3,000rpm		
Control box	Model name	PLK-J-CU-20		
	Rated output	DC 24V		
Condition	Power source	1KVA		
	Range of rating voltage	±10%		
	Ambient temperature	5°C to 35°C		
	Ambient humidity	45% to 85%		

mitsubishi
MITSUBISHI ELECTRIC CORPORATION

Printed in Japan